



# Industrial Lightweight Construction

High-quality fasteners for fixing profiled sheets and sandwich panels in the industrial lightweight construction sector

# At home in many trades

## Overview of our catalogues

Whether for professional applications on building facades or for anchoring solutions of technical facilities inside the building – EJOT offers the right fastening solution for every application.

Besides our comprehensive General Catalogue Building Fasteners, we offer you further catalogues on our business fields in addition to the individual catalogue Industrial Lightweight Construction. Unlike the printed general catalogue, the individual catalogues are available exclusively in digital form.

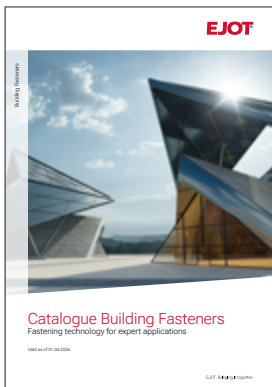
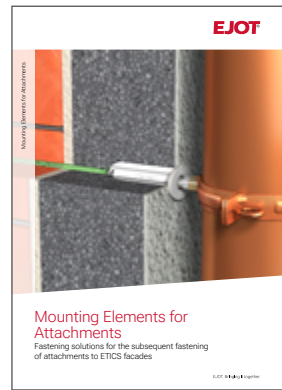
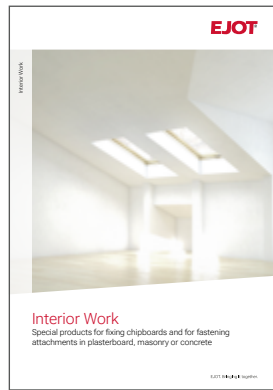
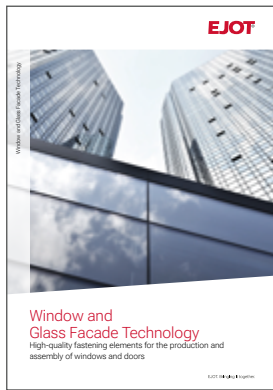
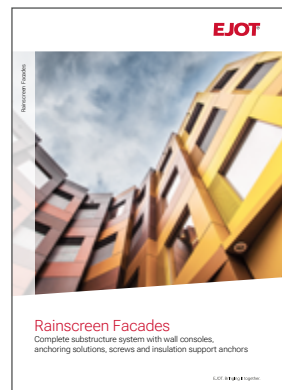
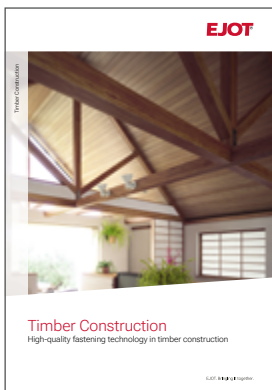

### General Catalogue Building Fasteners 2025/2026

You can find the current catalogue online as a PDF version.

You can find a digital overview of our catalogues here:



[www.ejot.com/catalogues](http://www.ejot.com/catalogues)

# Product overview

## EJOFAST® self-drilling screws

### JF2 (steel)

JF2-2H-4.8xL 28

### JF3 (A2 stainless steel + steel)

JF3-2H-4.8xL 42

JF3-FR-2-5.5xL 43

JF3-Plus-4.9xL 44

JF3-FR-Plus-4.9xL 45

JF3-Plus-6.8xL 46

## Self-drilling screws

### JT2 (steel)

JT2-2H-4.8xL EJOGUARD 29

JT2-3-4.8xL EJOGUARD 30

JT2-2H-Plus-5.5xL F12 EJOGUARD 31

JT2-6-5.5xL F12 EJOGUARD 32

JT2-6-6.3xL F12 EJOGUARD 33

JT2-12-5.5xL F12 EJOGUARD 34

JT2-18-5.5xL F12 EJOGUARD 35

JT2-FZ-6-6.3xL F12 EJOGUARD 36

JT2-FZ-12-6.3xL F12 EJOGUARD 37

JT2-FZ-F-6.5xL 38

JT2-ST-2-6.0xL EJOGUARD 39

JT2-ST-2-6.8xL EJOGUARD 40

JT2-WD-5-5.5xL EJOGUARD 41

### JT3 (A2 stainless steel + steel)

JT3-2H-4.8xL 48

JT3-FR-2H-4.8xL 49

JT3-2H-Plus-5.5xL 50

JT3-FR-2H-Plus-5.5xL 51

JT3-2-6.5xL 52

JT3-6-5.5xL 54

JT3-FR-6-5.5xL 56

JT3-6-6.3xL 57

JT3-12-5.5xL 58

JT3-FR-12-5.5xL 60

JT3-18-5.5xL 61

JT3-D-6H-5.5/6.3xL 62

JT3-D-12H-5.5/6.3xL 64

JT3-ST-2-6.0xL 68

JT3-X-2-6.0xL 69

JT3-WD-6-5.5xL 70

JT3-2H-40-6.0/6.0xL 71

JT3-2H-80-6.0/6.0xL 71

### JT4 (A2 stainless steel)

JT4-4-4.8xL 72

JT4-6-5.5xL 73

JT4-FR-2-4.9xL 74

JT4-FR-4-4.8xL 75

JT4-FR-4-5.5xL 76

JT4-FZ-6.5xL 77

### JT6 (A4 stainless steel + steel)

JT6-2H-Plus-5.5xL 78

JT6-6-5.5xL 79

JT6-12-5.5xL 80

## Concrete screw

### JC6 (A4 stainless steel)

JC6-D-7.5xL 67

## Self-tapping Screws

### JZ5 (A2 stainless steel + steel)

JZ5-6.3xL 84

JZ5-8.0xL 86

### JZ1 (A8 stainless steel)

JZ1-6.3xL 87

### JA1 (A8 stainless steel)

JA1-6.5xL 88

### JZ3 (Edelstahl A2)

JZ3-S-6.3xL 89

### JA3 (A2 stainless steel)

JA3-LT-4.9xL 90

JA3-S-6.5xL 91

### JB3 (A2 stainless steel)

JB3-7.2xL 92

## Clamping screw RLS

### RLS (A2 stainless steel )

RLS-25xL 93

## ORKAN Storm Washers

Trapezoidal profile 95

Corrugated profile 101

## ECORIV® rivets

### Closed-end rivets

AL/E 4.8xL 110

### Multigrip rivets

AL/E 4.0xL 111

AL/E 4.8xL 111

### Folding blind rivets

ALU 5.2xL 113

## Metal construction fasteners

### Metal construction anchors

#### (A2 stainless steel)

JA3-GU-6.5xL 115

JZ5-GU-6.3xL 116

### Ring bolts

GU ring bolt 117

### Threaded sleeves

GU threaded sleeve 117

## DEKTITE®

### Pipe flashings

#### Pipe flashings

DEKTITE® Square Set 119

DEKTITE® EZi-Seal Set 120

DEKTITE® Soaker Set 121

DEKTITE® Combo Set 122

DEKTITE® Strip Flash Set 123

### Accessories

EJOPLAST joint sealant 124

Cable tie set 124

Tightener 124

Fastener strap 124

Hose clamp 125

## Washers

### Sealing washers (A2 stainless steel)

Sealing washer E 126

Pilzdichtung 127

### Shearing load washers (Steel)

Shearing load washer VS 127

## Thread protection sleeve

Thread protection sleeve RAL 9002 128

## Sealing tapes

TP310 130

TP610 131

ISO-Zell-PE Tape 132

## Profile fillers

ISO profile filler strips 133

## Machinery

### Cordless screwdrivers

ASCM 18 QSW AS 135

### Cordless impact screwdrivers

ASCD 18-300 W2 AS 136

### Cordless hammer drill

ABH 18-26 AS 137

### Cordless riveting tools

ECORIV® ONE 16.0V / 2.0 Ah 138

## Tools

### Precision drill bit HSS

Drill bit S 139

### Hammer drill SDS plus®

4-edge SDS-plus 140

### Socket wrench inserts

K-SW/ S-SW 141

### Bits

Hexalobular TX 142

### Bit holder

BT-1/4"-1/4"xL 143

### Fastening tools

FR Tool 143

FR Tool plastic 144

## EJOT® product key for self-drilling and self-tapping screws

This is how you apply the product key on the example of an

### EJOT self-drilling screw JT3-FR-2H-4.8x19-E11-9006

- > with sealing washer E11
- > colour version RAL 9006

<b>Example</b>	<b>J</b>	<b>T</b>	<b>3</b>	-	<b>FR</b>	-	<b>2</b>	<b>H</b>	-	<b>4.8</b>	x	<b>19</b>	-	<b>E</b>	<b>11</b>	-	<b>9006</b>	
<b>EJOT</b>	<b>J</b>																	
<b>Screw type</b>																		
Concrete screw		<b>C</b>																
Self-drilling screw		<b>T</b>																
EJOFAST® self-drilling screw		<b>F</b>																
Self-tapping screw coarse thread with point		<b>A</b>																
Self-tapping screw fine pitch thread with dog point		<b>Z</b>																
Self-tapping screw fine pitch thread with point		<b>B</b>																
<b>Self-drilling screw material</b>																		
Case-hardened steel, zinc-plated			<b>2</b>															
A2 stainless steel with hardened steel point			<b>3</b>															
A4 stainless steel with hardened steel point			<b>6</b>															
A2 stainless steel			<b>4</b>															
A4 stainless steel			<b>9</b>															
<b>Self-tapping screw material</b>																		
A8 stainless steel / CORREMAKS®			<b>1</b>															
Zinc-plated steel			<b>2</b>															
A2 stainless steel			<b>3</b>															
A2 stainless steel with hardened steel dog point			<b>5</b>															
A2 stainless steel / CRONIMAKS			<b>7</b>															
<b>Version</b>																		
Standard (hexagon)																		
Truss head					<b>FR</b>													
Hexalobular TX drive					<b>T/TX</b>													
Distance					<b>D</b>													
Special head geometry					<b>X</b>													
Countersunk head with hexalobular TX					<b>ST</b>													
Countersunk flange head with hexalobular TX					<b>STS</b>													
Countersunk head TX ribs					<b>STR</b>													
Cheese head with hexalobular TX					<b>ZT</b>													
Countersunk head					<b>S</b>													
Pan head with hexalobular TX					<b>LT</b>													
Pan head with hexalobular TX and cutting ring					<b>XT</b>													
Fibre cement					<b>FZ</b>													
Drill point with wings (Wing Drill)					<b>WD</b>													
Max. drillable metal thickness								<b>[mm]</b>										
Free spin zone under screw head									<b>H</b>									
Screw diameter										<b>[mm]</b>								
Screw length											<b>[mm]</b>							
<b>Sealing washer material</b>																		
Zinc-plated steel														<b>V</b>				
A2 stainless steel														<b>E</b>				
Aluminium														<b>A</b>				
Sealing washer diameter															<b>[mm]</b>			
Colour (4-digit RAL number)																		<b>[RAL]</b>

## Screws types in industrial lightweight construction

## Point styles

Self-drilling screw  
(JT)Drill point with wings  
(WD)EJOFAST®  
screw point geometry  
(JF)Fine pitch thread  
with dog point  
(JZ)Coarse thread  
with point  
(JA)Fine pitch thread  
with point  
(JB)

## Drives

Standard  
hexagon head  
(SW)Hexalobular TX drive  
(T/TX)

## Head geometries and versions

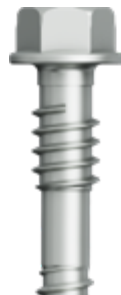
Special head ge-  
ometry  
(X)Countersunk flange  
head with hexalobular  
TX (STS)Cheese head  
with hexalobular TX  
(ZT)Truss head  
(FR)Pan head with hex-  
alobular  
(TX)Countersunk head  
with hexalobular TX  
and milling ribs  
(ST)Countersunk head  
(S)High thread  
with distance  
(D)Fibre cement  
(FZ)

## Technical abbreviations

Abbreviation	Description	Unit
$d_{sw}$	Pre-drilled hole in sandwich panel	mm
DC	Drilling capacity	mm
L	Length	mm

Abbreviation	Description	Unit
$l_g$	Thread length	mm
SW	Wrench size	mm

## Tin tile roof

### Description

Single-sheet uninsulated profile roof, purlin design. The roof cladding is fastened to wooden slats and it is weather-exposed.

### Application

- > Roof overhangs
- > Sheds
- > Carports

## Single-sheet profile roof

### Description

Single-sheet uninsulated profile roof, purlin design. The roof cladding is directly fastened to the purlins and it is weather-exposed.





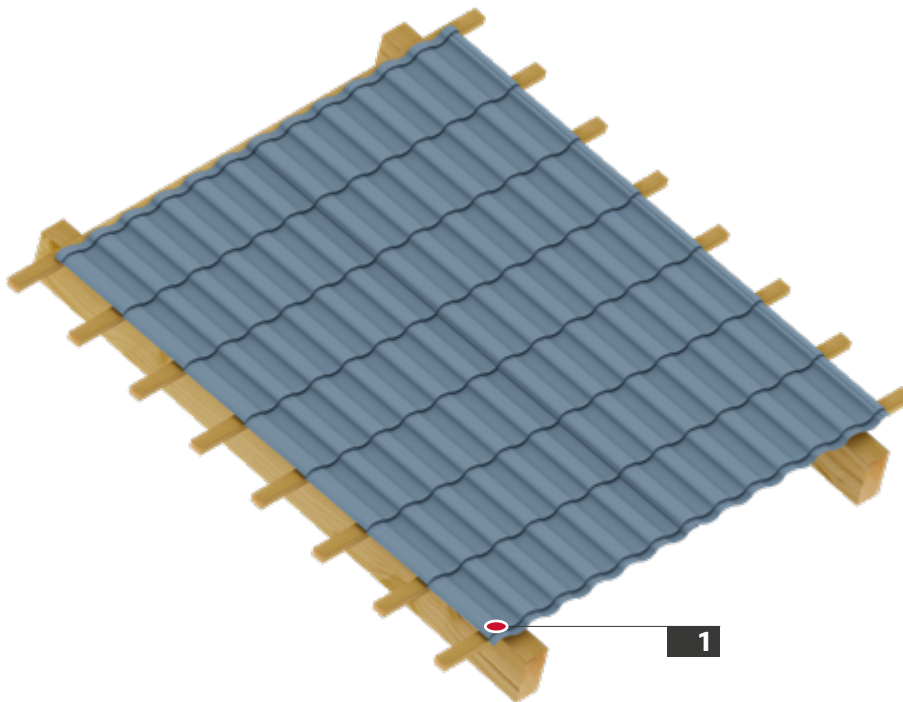

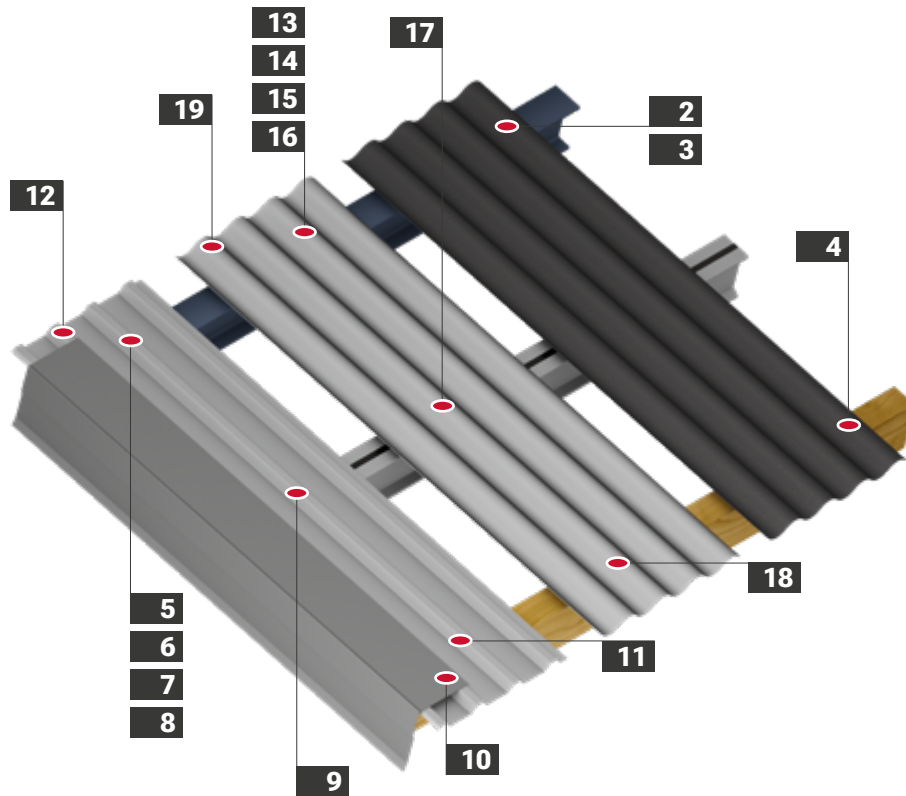

### Application









- > Roof overhangs
- > Sheds
- > Carports



No.	Application	Product	Page
1	 Roofing sheet to timber substructure	Self-drilling screw JF3-Plus-4.9x35 E14	44



No.	Application	Product	Page
2	 Fibre cement board to 1.5-5.0 mm steel purlin	Self-drilling screw JT2-FZ-6-6.3 F12	36
3	 Fibre cement board to 4.0-12.0 mm steel purlin	Self-drilling screw JT2-FZ-12-6.3 F12	37
4	 Fibre cement board to timber purlin min. width 65 mm	Self-drilling screw JT2-FZ-F-6.5 F12	38
5	 Trapezoidal profile to 1.5-4.0 mm steel purlin	Self-drilling screw JT3-6-5.5xL-E16 + ORKAN storm washer	54
6	 Trapezoidal profile to 4.0-10.0 mm steel purlin	Self-drilling screw JT3-12-5.5xL-E16 + ORKAN storm washer	58
7	 Trapezoidal profile to 4.0-16.0 mm steel purlin	Self-drilling screw JT3-18-5.5xL-E16 + ORKAN storm washer	61
8	 Trapezoidal profile to steel purlin ≥ 1.5 mm	Self-tapping screw JZ5-6.3xL-E16 + ORKAN storm washer	84
9	 Trapezoidal profile to 3.0 mm insertion rail	Self-tapping screw JZ5-6.3xL-E16 + ORKAN storm washer	84
10	 Fastening flashings to trapezoidal profile 2 x 0.88 mm	EJOFAST® self-drilling screw JF3-2H-4.8x19-E14	42

No.	Application	Product	Page
11	 Trapezoidal profile to timber purlin min. width 60 mm	EJOFAST® self-drilling screw JF3-plus -6.8xL-E16 + ORKAN storm washer	46
12	 Side lap stitching of trapezoidal profile ≤ 2 x 0.88 mm	EJOFAST® self-drilling screw JF3-2H-4.8x19-E14	42
13	 Corrugated profile sheet to 1.5 - 4.0 mm steel purlin	Self-drilling screw JT3-6-5.5xL-E16 + ORKAN storm washer	54
14	 Corrugated profile sheet to 4.0 - 10.0 mm steel purlin	Self-drilling screw JT3-12-5.5xL-E16 + ORKAN storm washer	58
15	 Corrugated profile sheet to 4.0 - 16.0 mm steel purlin	Self-drilling screw JT3-18-5.5xL-E16 + ORKAN storm washer	61
16	 Corrugated profile sheet to steel purlin ≥ 1.5 mm	Self-tapping screw JZ5-6.3xL-E16 + ORKAN storm washer	84
17	 Corrugated profile sheet to 3.0 mm insertion rail	Self-tapping screw JZ5-6.3xL-E16 + ORKAN storm washer	84
18	 Corrugated profile sheet to timber purlin min. width 60 mm	EJOFAST® self-drilling screw JF3-plus -6.8xL-E16 + ORKAN storm washer	46
19	 Side lap stitching of corrugated profile sheet	EJOFAST® self-drilling screw JF3-2H-4.8x19-E14	42

## Double-sheet profile roof

### Description

On the inside, the supporting shell is first fastened to the steel or timber purlins. The exterior roof shell is kept apart through thin-walled spacer profiles. The external roof shell serves for weather protection, the internal load-bearing shell for load bearing.

### Application







> Heated buildings of all kinds and scope

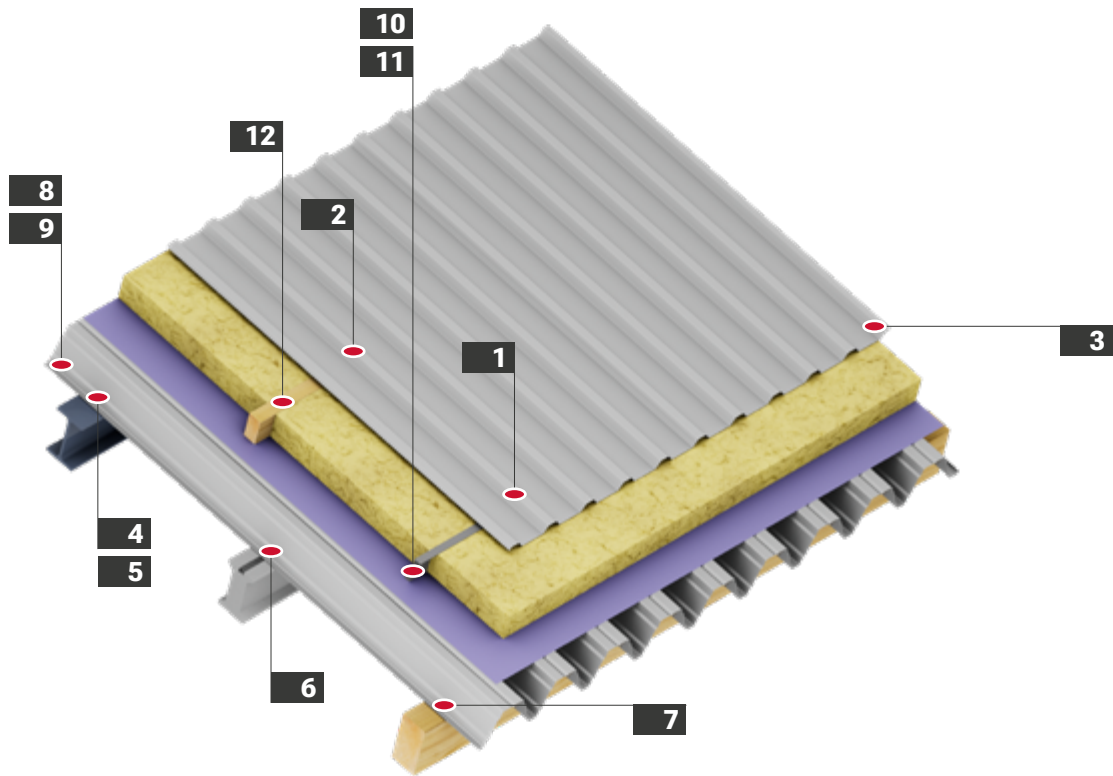





### Determination of the screw lengths

h = height of trapezoidal or corrugated profile, L = screw length,  $t_{fix}$  = clamp thickness

Load-bearing shell to steel substructure		Load-bearing shell to insertion rail		Load-bearing shell to Timber substructure		Trapezoidal profile to steel purlin		Trapezoidal profile to timber purlin			
1.5 – 5.0 mm		4.0 – 10.0 mm		3.0 mm		min. width 60 mm		1.5 – 4.0 mm		min. width 60 mm	
JT2-6-5.5x25 F12 V16		JT2-12-5.5x35 F12 V16		JT2-6-5.5x25 F12 V16		JF3-Plus-6.8xL -E16		JT3-6-5.5xL-E16 + ORKAN storm washer		JF3-plus -6.8xL-E16 + ORKAN storm washer	
$t_{fix}$ [mm]	L [mm]	$t_{fix}$ [mm]	L [mm]	$t_{fix}$ [mm]	L [mm]	h [mm]	L [mm]	h [mm]	L [mm]	h [mm]	L [mm]
0 – 10	25	0 – 10	35	0 – 10	25	-	40	-	-	-	-
-	-	-	-	-	-	-	60	-	-	-	-
-	-	-	-	-	-	-	80	20 – 40	70	0 – 30	80
-	-	-	-	-	-	-	-	40 – 60	90	20 – 50	100
-	-	-	-	-	-	-	-	60 – 80	110	40 – 70	120
-	-	-	-	-	-	-	-	80 – 100	130	60 – 90	140
-	-	-	-	-	-	-	-	100 – 120	150	80 – 110	160
-	-	-	-	-	-	-	-	120 – 140	170	100 – 130	180
-	-	-	-	-	-	-	-	140 – 160	190	120 – 150	200
-	-	-	-	-	-	-	-	-	-	140 – 170	220
-	-	-	-	-	-	-	-	-	-	160 – 190	240
-	-	-	-	-	-	-	-	-	-	180 – 210	260
-	-	-	-	-	-	-	-	-	-	200 – 230	280
-	-	-	-	-	-	-	-	-	-	220 – 250	300



No.	Application	Product	Page
1	 Trapezoidal profile to 1.5-4.0 mm steel purlin	Self-drilling screw JT3-6-5.5xL-E16 + ORKAN storm washer	54
2	 Trapezoidal profile to timber purlin min. width 60 mm	EJOFAST® self-drilling screw JF3-plus -6.8xL-E16 + ORKAN storm washer	46
3	 Side lap stitching of trapezoidal profile ≤ 2 x 0.88 mm	EJOFAST® self-drilling screw JF3-2H-4.8x19-E14	42
4	 Load-bearing shell to 1.5-4.0 mm steel purlin	Self-drilling screw JT2-6-5.5x25 F12 V16	32
5	 Load-bearing shell to 4.0-10.0 mm steel purlin	Self-drilling screw JT2-12-5.5x40 F12 V16	34
6	 Load-bearing shell to 3.0 mm insertion rail	Self-drilling screw JT2-6-5.5x25 F12 V16	32

No.	Application	Product	Page
7	 Load-bearing shell to timber purlin min. width 60 mm	EJOFAST® self-drilling screw JF3-Plus-6.8xL -E16	46
8	 Side lap stitching of load-bearing shell ≤ 2 x 0.88 mm	EJOFAST® self-drilling screw JF2-2H-4.8x19	28
9	 Side lap stitching of load-bearing shell 2 x 1.0-2 x 1.5 mm	Self-drilling screw JT2-3-4.8x19	30
10	 Steel spacer 1.5-2.0 mm to load-bearing shell	Self-drilling screw JT2-2H-Plus-5.5x25 F12 V16	31
11	 Steel spacer profile > 1.5 mm to supporting shell	Folding blind rivet ECORIV Alu 5.2xL	113
12	 Spacer wood to load-bearing shell	Self-drilling screw JT3-ST-2-6.0xL	68

## Double-sheet roof with seam or clamping profile

### Description

On the inside, the supporting shell is first fastened to the steel or timber purlins. The clips for fixing standing seam systems are fastened with self-drilling screws, either directly to the load-bearing shell or indirectly to an additional spacer. The outer shell is fixed to the clips with a folding machine.

### Notice

The JT3-X-2-6.0xL self-drilling screw is a building authorities-approved product to fasten clips to sub-structures made of steel, timber or aluminium. Every clip must be fixed with 2 screws in the order shown opposite. The special feature of the screw are the grooves under the head. They are able to considerably increase the stripping torque, which leads to an increased installation reliability. Sealing washers have to be used for set-up 1.

### Application

- > Heated buildings of all kinds and scope
- > Arched roofs
- > Barrel roofs

### Position of the fastening elements

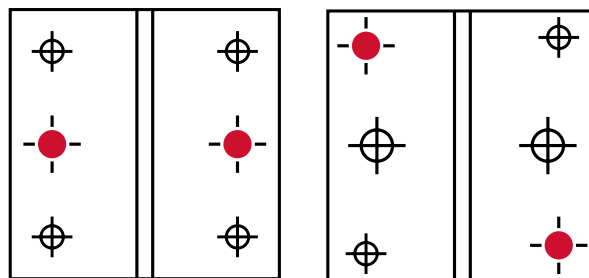

**Set-up 1**  
(sealing washers must be used)

**Set-up 2**

### Determination of the screw lengths



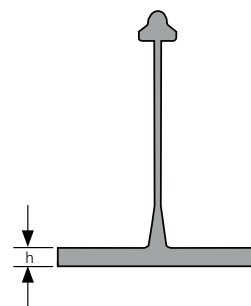

h = dedendum of the clip, L = screw length



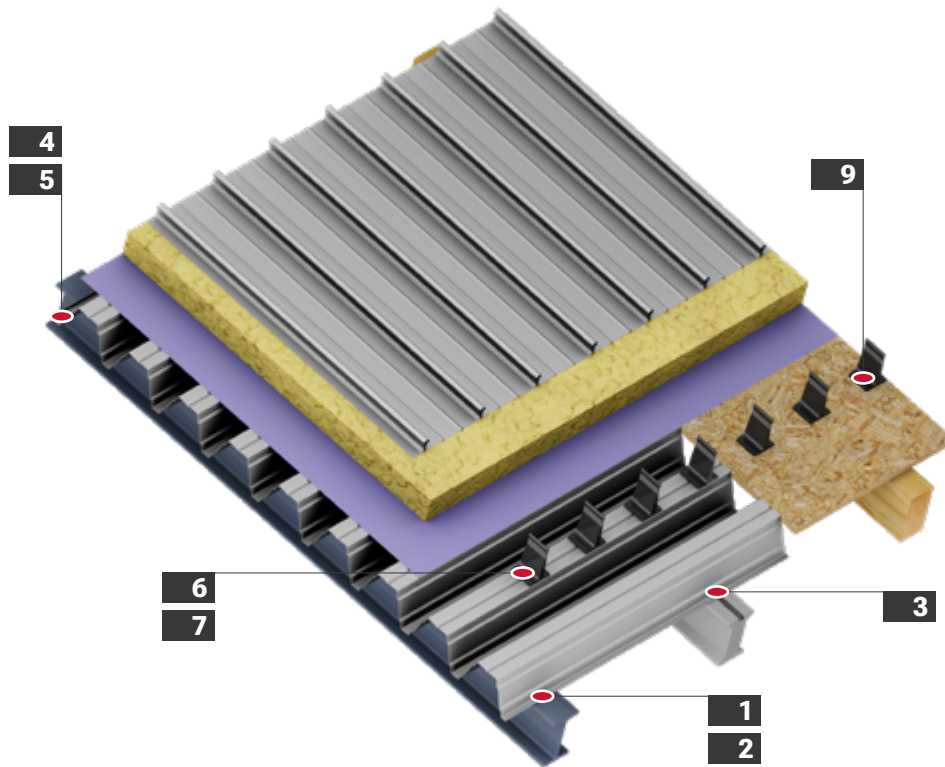



Clip to steel substructure								Clip to roof boarding / OSB boards	
JF3-2-5.5xL-E16*		JF3-2-6.0xL-E16*		JT3-X-2-6.0xL		JT3-6-5.5xL-E16		JT3-X-2-6.0xL	
h [mm]	L [mm]	h [mm]	L [mm]	h [mm]	L [mm]	h [mm]	L [mm]	h [mm]	L [mm]
0 - 10	35	0 - 5	25	0 - 10	25	0 - 5	25	0 - 5	36
-	-	0 - 20	40	0 - 20	36	0 - 10	30	0 - 15	46
-	-	0 - 30	50	0 - 30	46	0 - 15	35	-	-
-	-	-	-	-	-	20 - 30	50	-	-

\*see chapter solar



No.	Application	Product	Page
1	 Tragschale auf Stahlpfette 1,5 – 4,0 mm	Bohrschraube JT2-6-5,5x25 F12 V16	32
2	 Tragschale auf Stahlpfette 4,0 – 10,0 mm	Bohrschraube JT2-12-5,5x40 F12 V16	34
3	 Tragschale auf Einlegeschiene 3,0 mm	Bohrschraube JT2-6-5,5x25 F12 V16	32
4	 Längsstoßverschraubung Tragschale ≤ 2 x 0,88 mm	EJOFAST® Bohrschraube JF2-2H-4,8x19	28

No.	Application	Product	Page
5	 Längsstoßverschraubung Tragschale 2 x 1,0–2 x 1,5 mm	Bohrschraube JT2-3-4,8x19	30
6	 Klipp auf Distanzprofil ≤ 1,5 mm	Bohrschraube JT3-X-2-6,0xL	69
7	 Klipp auf eingefräste Systemschiene ≤ 1,5 mm	Bohrschraube JT3-X-2-6,0xL	69
8	 Klipp auf Holzschalung/OSB-Platten	Bohrschraube JT3-X-2-6,0xL	69

## Sandwich panel roof

### Description

Sandwich panels are composite elements. They consist of two metallic layers that are usually connected with polyurethane foam or mineral wool so they are shear-resistant. Sandwich panels are fastened directly to the substructure. The following element is pushed to the assembled element from the side and then fastened.

### Application





> Heated buildings of all kind and scope



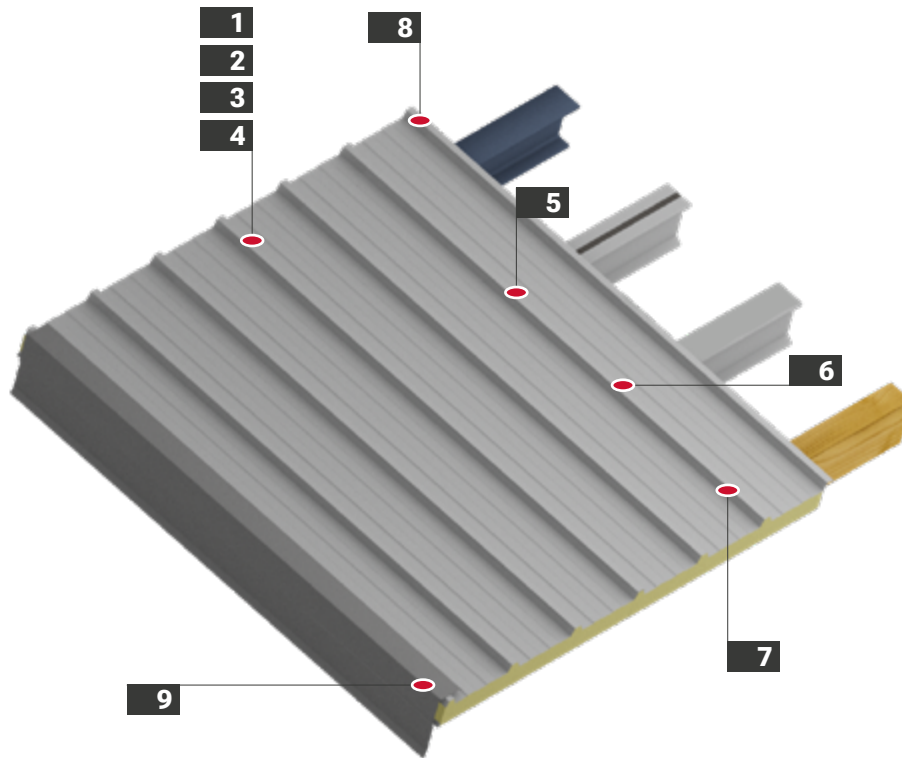

### Determination of the screw lengths

h = height sandwich panel or corrugated profile, L = screw length

Sandwich panel to steel substructure				Sandwich panel to insertion rail				Sandwich panel to Timber substructure			
≥ 1.5 mm		1.5 – 4.0 mm		4.0 – 10.0 mm		4.0 – 16.0 mm		3.0 mm		min. width 60 mm	
JZ5-6.3xL-E16 + ORKAN storm washer		JT3-6-5.5xL-E16 + ORKAN storm washer		JT3-12-5.5xL-E16 + ORKAN storm washer		JT3-18-5.5xL-E16 + ORKAN storm washer		JZ5-6.3xL-E16 + ORKAN storm washer		JF3-Plus-6.8xL-E16 + ORKAN storm washer	
h [mm]	L [mm]	h [mm]	L [mm]	h [mm]	L [mm]	h [mm]	L [mm]	h [mm]	L [mm]	h [mm]	L [mm]
40	53	-	-	-	-	-	-	27 – 37	53	-	65
40	63	-	-	-	-	-	-	37 – 47	63	-	80
40 – 55	83	20 – 40	70	20 – 40	78	-	-	57 – 67	83	20 – 45	100
40 – 70	93	40 – 60	90	40 – 60	98	40 – 60	115	67 – 77	93	40 – 65	120
40 – 80	103	60 – 80	110	60 – 80	118	80 – 100	155	77 – 87	103	60 – 85	140
50 – 95	113	80 – 100	130	80 – 100	138	120 – 140	195	87 – 97	113	80 – 105	160
60 – 105	123	100 – 120	150	100 – 120	158	160 – 180	235	97 – 107	123	100 – 125	180
70 – 115	133	120 – 140	170	120 – 140	178	200 – 220	275	107 – 117	133	120 – 145	200
80 – 125	143	140 – 160	190	140 – 160	198	-	-	117 – 127	143	140 – 165	220
90 – 135	153	-	-	-	-	-	-	127 – 137	153	160 – 185	240
100 – 145	163	-	-	-	-	-	-	137 – 147	163	180 – 205	260
120 – 165	183	-	-	-	-	-	-	157 – 167	183	200 – 225	280
140 – 185	203	-	-	-	-	-	-	177 – 187	203	220 – 245	300
160 – 205	223	-	-	-	-	-	-	-	-	-	-
180 – 225	243	-	-	-	-	-	-	-	-	-	-
200 – 245	263	-	-	-	-	-	-	-	-	-	-



No.	Application	Product	Page
1	 Sandwich panel to 1.5-4.0 mm steel purlin	Self-drilling screw JT3-6-5.5xL-E16 + ORKAN storm washer	54
2	 Sandwich panel to 4.0-10.0 mm steel purlin	Self-drilling screw JT3-12-5.5xL-E16 + ORKAN storm washer	58
3	 Sandwich panel to 4.0-16.0 mm steel purlin	Self-drilling screw JT3-18-5.5xL-E16 + ORKAN storm washer	61
4	 Sandwich panel to steel purlin ≥ 1.5 mm	Self-tapping screw JZ5-6.3xL-E16 + ORKAN storm washer	84
5	 Sandwich panel to insertion rail 3.0 mm	Self-tapping screw JZ5-6.3xL-E16 + ORKAN storm washer	84

No.	Application	Product	Page
6	 Sandwich panel to concrete substructure	Concrete screw JC6-D-7.5 + ORKAN storm washer	67
7	 Sandwich panel to timber purlin min. width 60 mm	EJOFAST® self-drilling screw JF3-plus -6.8xL + ORKAN storm washer	46
8	 Side lap stitching of sandwich panel	EJOFAST® self-drilling screw JF3-2H-4.8x19-E14	42
9	 Fastening flashing to sandwich panel	EJOFAST® self-drilling screw JF3-2H-4.8x19-E14	42

## Profiled wall with cassette structure







### **Description**

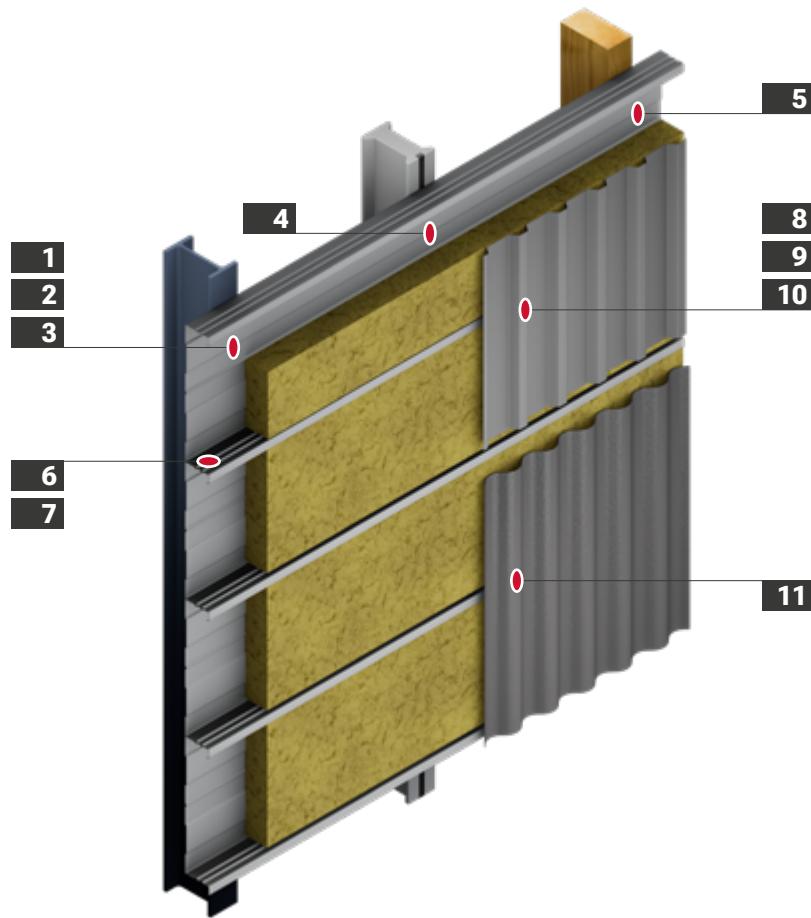



The cassette is directly fastened to steel supports. The outer sheet is fastened to the cassette bars and does not only serve as weather protection but also as bracing for the cassettes. The cassette system walls serve as noise and fire protection.

### **Application**

- > Heated buildings
- > Buildings with high noise level
- > Buildings with increased demands on fire protection
- > Buildings with process heat



No.	Application	Product	Page
1	 Cassette to 1.5-4.0 mm steel purlin	Self-drilling screw JT2-6-5.5x25 F12 V16	32
2	 Cassette to 4.0-10.0 mm steel purlin	Self-drilling screw JT2-12-5.5x40 F12 V16	34
3	 Cassette to 4.0-16.0 mm steel purlin	Self-drilling screw JT2-18-5.5x40 F12 V16	35
4	 Cassette to 3.0 mm insertion rail	Self-drilling screw JT2-6-5.5x25 F12 V16	32
5	 Cassette to timber purlin min. width 60 mm	EJOFAST® self-drilling screw JF3-Plus-6.8xL -E16	46
6	 Cassette side lap stitching ≤ 2 x 0.88 mm	EJOFAST® self-drilling screw JF2-2H-4.8x19	28

No.	Application	Product	Page
7	 Cassette side lap stitching 2 x 1.0-2 x 1.5 mm	Self-drilling screw JT2-3-4.8x19	30
8	 Trapezoidal profile to 2 x 0.63-2 x 1.25 mm cassette	Self-drilling screw JT3-2H-Plus-5.5xL-E16	50
9	 Trapezoidal and top-hat profile on 40 mm insulated cassette	Self-drilling screw JT3-2H-40-6.0/6.0x64-E16	71
10	 Trapezoidal and top-hat profile on 80 mm insulated cassette	Self-drilling screw JT3-2H-80-6.0/6.0x64-E16	71
11	 Corrugated profile sheet to 2 x 0.63-2 x 1.25 mm cassette	Self-drilling screw JT3-FR-2H-Plus-5.5xL-E11	51

## Wall with sandwich panels

### Description

Sandwich panels are composite elements. They consist of two metallic layers that are usually connected with polyurethane foam or mineral wool so they are shear-resistant. The ratio of weight to load-bearing capacity is unbeatable. Sandwich panels are fastened directly to the substructure. The following element is pushed to the assembled element from the side and then fastened.

In the case of non-visible fastening, the proof of usability (approval) of the sandwich elements must be taken into account when selecting the screws.

### Application

> Heated buildings of all sizes and scope

### Notice

When using screws with high thread (JT3-D) indentations at the fixing points of sandwich panels can be reduced.

With a deep control oriented fastening, dent formation can be reduced.

| see page 135, cordless screwdriver ASCM 18 QSW AS

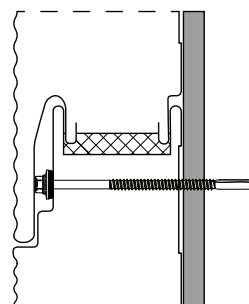

**Fig. 1**  
Not visible sandwich panel installation

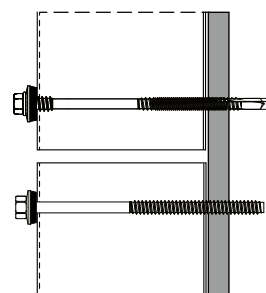
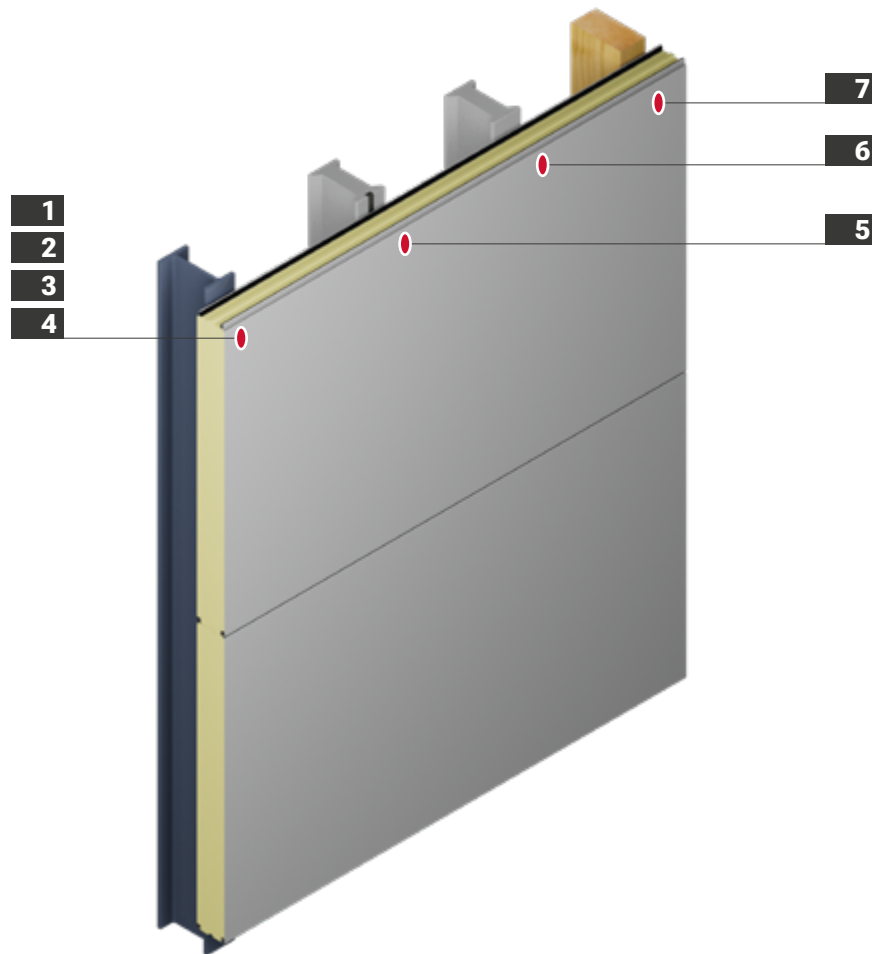





**Fig. 2**  
Visible sandwich panel installation



### Determination of the screw lengths

h = height sandwich panel, L = screw length

Sandwich panel to steel substructure								Sandwich panels to insertion rail		Sandwich panel to Timber substructure	
≥ 1.5 mm		1.5 – 4.0 mm		4.0 – 10.0 mm		4.0 – 16.0 mm		3.0 mm		min. width 60 mm	
JZ5-6.3xL-E19		JT3-D-6H-5.5/6.3xL-E19		JT3-D-12H-5.5/6.3xL-E19		JT3-18-5.5xL-E19		JZ5-6.3xL-E19		JF3-Plus-6.8xL-E19	
h [mm]	L [mm]	h [mm]	L [mm]	h [mm]	L [mm]	h [mm]	L [mm]	h [mm]	L [mm]	h [mm]	L [mm]
0 – 30	50	-	-	40 – 42	75	-	-	25 – 33	50	-	-
3 – 44	64	35 – 40	67	50 – 62	95	-	-	39 – 47	64	20 – 45	100
19 – 60	80	42 – 60	87	60 – 82	115	40 – 60	115	55 – 63	80	40 – 65	120
29 – 70	90	52 – 80	107	75 – 102	135	80 – 100	155	65 – 73	90	60 – 85	140
39 – 80	100	72 – 100	127	95 – 122	155	120 – 140	195	75 – 83	100	80 – 105	160
54 – 95	115	92 – 120	147	115 – 142	175	160 – 180	235	90 – 98	115	100 – 125	180
64 – 105	125	112 – 140	167	135 – 162	195	200 – 220	275	100 – 108	125	120 – 145	200
74 – 115	135	140 – 170	197	145 – 182	215	-	-	110 – 118	135	140 – 165	220
89 – 130	150	170 – 210	237	175 – 212	245	-	-	125 – 133	150	160 – 185	240
114 – 155	175	200 – 240	267	205 – 242	275	-	-	150 – 158	175	180 – 225	280
139 – 180	200	-	-	235 – 272	300	-	-	175 – 183	200	220 – 245	300



No.	Application	Product	Page
1	 Sandwich panel to 1.5-4.0 mm steel purlin	Self-drilling screw JT3-D-6H-5.5/6.3xL-E19	62
2	 Sandwich panel to 3.0-12.0 mm steel purlin	Self-drilling screw JT3-D-12H-5.5/6.3xL-E19	64
3	 Sandwich panel to 4.0-16.0 mm steel purlin	Self-drilling screw JT3-18-5.5xL-E19	61
4	 Sandwich panel to steel purlin $\geq$ 1.5 mm	Self-tapping screw JZ5-6.3xL-E19	84

No.	Application	Product	Page
5	 Sandwich panel to insertion rail 3.0 mm	Self-tapping screw JZ5-6.3xL-E19	84
6	 Sandwich panel to concrete substructure	Concrete screw JC6-D-7.5	67
7	 Sandwich panel to timber purlin min. width 60 mm	EJOFAST® self-drilling screw JF3-Plus-6.8xL -E19	46

## Single-sheet profiled wall







### Description

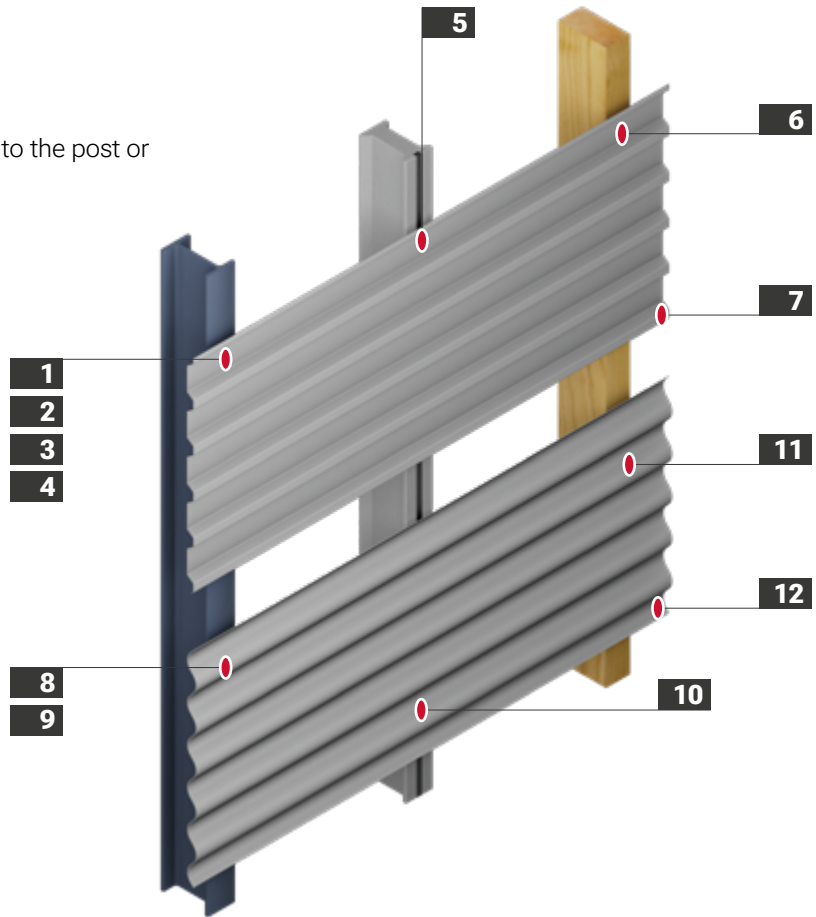





The profiled sheet is directly fastened to the post or rail and it is weather-exposed.

### Application

- > Simple sheds
- > Carports
- > Bicycle sheds



No.	Application	Product	Page
1	 Trapezoidal profile to 1.5-4.0 mm steel purlin	Self-drilling screw JT3-6-5.5xL-E16	54
2	 Trapezoidal profile to 4.0-10.0 mm steel purlin	Self-drilling screw JT3-12-5.5xL-E16	58
3	 Trapezoidal profile to 4.0-16.0 mm steel purlin	Self-drilling screw JT3-18-5.5xL-E16	61
4	 Trapezoidal profile to steel purlin $\geq 1.5$ mm	Self-tapping screw JZ5-6.3xL-E16	84
5	 Trapezoidal profile to 3.0 mm insertion rail	Self-drilling screw JT3-6-5.5x25 E16	54
6	 Trapezoidal profile to timber purlin min. width 60 mm	EJOFAST® self-drilling screw JF3-Plus-6.8xL -E16	46

No.	Application	Product	Page
7	 Side lap stitching of trapezoidal profile $\leq 2 \times 0.88$ mm	EJOFAST® self-drilling screw JF3-2H-4.8x19-E14	42
8	 Corrugated aluminium profile sheet to 1.5-4.0 mm steel purlin	Self-drilling screw JT3-FR-6-5.5xL-E11	56
9	 Corrugated aluminium profile sheet to 4.0-10.0 mm steel purlin	Self-drilling screw JT3-FR-12-5.5xL-E11	60
10	 Corrugated aluminium profile sheet to 3.0 mm insertion rail	Self-drilling screw JT3-FR-6-5.5x25-E11	56
11	 Corrugated aluminium profile sheet to timber purlin min. width 40 mm	EJOFAST® self-drilling screw JF3-FR-Plus-4.9x35 E11	45
12	 Side lap stitching of corrugated aluminium profile sheet $\leq 2 \times 0.88$ mm	Self-drilling screw JT3-FR-2H-4.8-E11	49

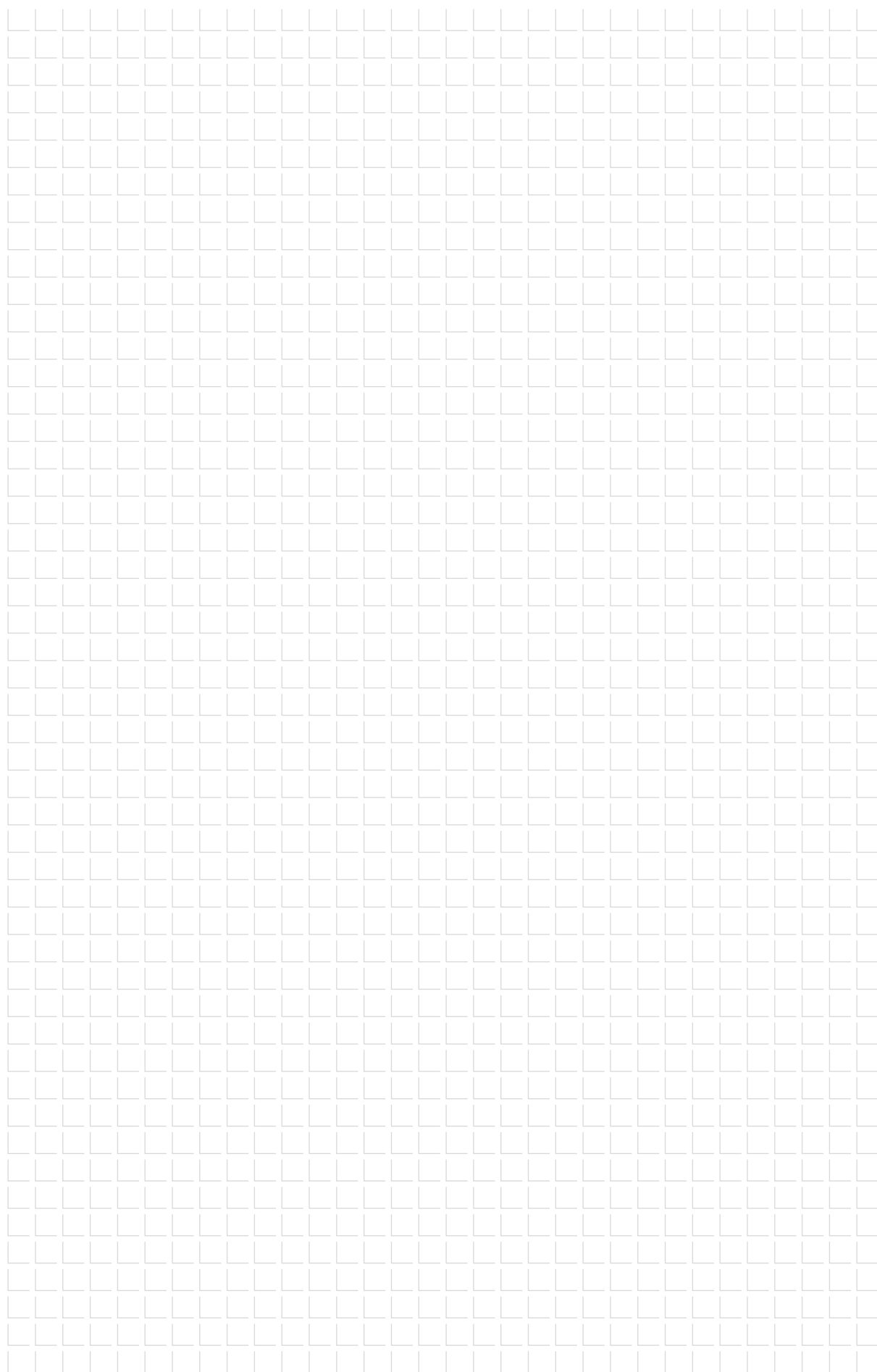

# EJOFAST® self-drilling screws

Clever & Clean Our strongest, cleanest and safest self-drilling screw

The new EJOFAST® Plus self-drilling screws, with their concave and particularly slender point, enable significantly safer placement on the surface and a high screwing speed. Displacement or slipping is almost impossible. At the same time, the load-bearing capacity values were improved once again. The slim, single-flighted drill point produces no sharp-edged chips that get stuck in the material and thus the amount of cleaning is reduced.

**Video EJOFAST family**

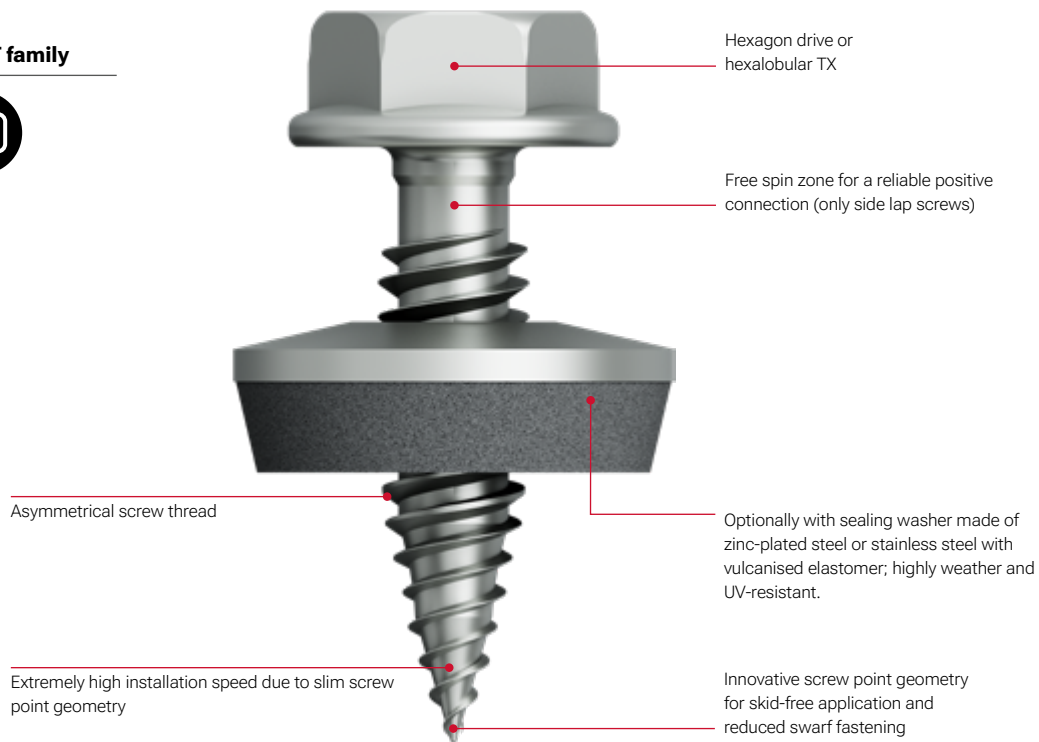

## Product overview EJOFAST® self-drilling screws

	JF2-2-4.2	JF2-2H-4.8	JF3-2H-4.8	JF3-2-5.5*	JF3-2-6.0*	JF3-Plus-4.9	JF3-Plus-6.8
<b>Self-drilling screws with innovative point geometry</b>							
<b>Material</b>	Case-hardened steel, protected against corrosion		A2 stainless steel with hardened steel drill point				
<b>For components made of</b>	Steel		Steel or aluminium			Steel or aluminium on timber	
<b>Max. drilling capacity steel [mm]</b>	0.75 + 0.75		0.88 + 0.88			0.88	
<b>*see chapter solar</b>							



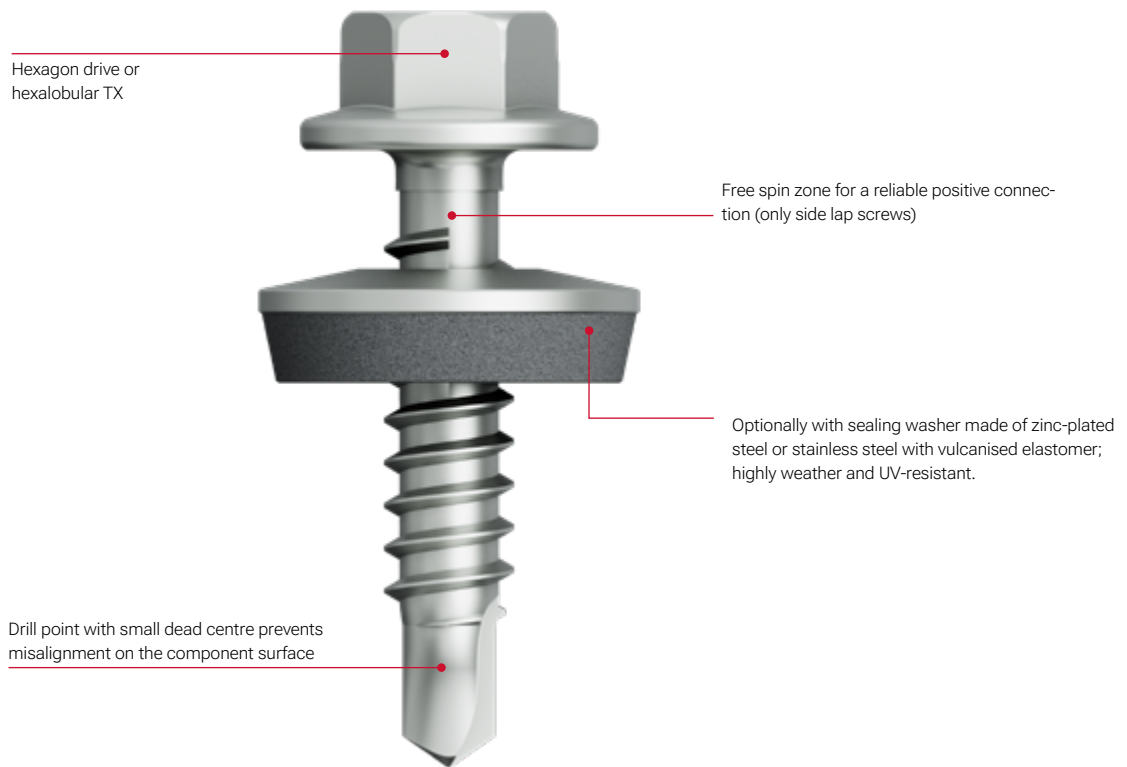

# Self-drilling screws

The classic drill point with cutting bit

The self-drilling EJOT screws feature a classic cutting bit. They drill a hole, form the female thread and fasten components in just one work step. The self-drilling screws are completed by an optional pre-assembled sealing washer.



## Product overview self-drilling screws

	JT2	JT3	JT6	JT4	JT9
<b>Self-drilling screws with classic drill point</b>					
<b>Material</b>	Steel Case-hardened, protected against corrosion	A2 stainless steel with hardened steel drill point	A4 stainless steel with hardened steel drill point	A2 stainless steel	A4 stainless steel
<b>For components made of</b>	Steel	Steel or aluminium		Aluminium	
<b>Max. drilling capacity [mm]</b>	18.0			6.0	

# Self-drilling screw selection

Drilling capacity and required clamp thickness have to be specified

## Determination of the screw length of self-drilling screws

The clamp thickness  $t_{fix}$  is the area of a self-drilling screw which can be used to connect two components. The components are clamped in this area (absorption and transfer of forces and loads in accordance with the respective technical approvals and assessments).

**Important: The clamping thickness does not equal the threaded part of a screw minus the length of the drill point!**

Therefore:

- > The first thread turns of a self-drilling screw are **not** suitable for clamping.
- > With bi-met screws (JF3/JF6, JT3/JT6) the drill point and the first thread turns are made of one hardened steel part. This part is used exclusively for the assembly process of the screw and must not be used for clamping.
- > The clamping thicknesses of the self-drilling screws can be found in the tables on the product-specific pages.
- > Cutting off the drill points is not permitted!

The required clamping thickness of a self-drilling screw is calculated from the material thickness of the components to be clamped (Fig. 1). For this, the thicknesses of components I and II, any intermediate layer and additional elements (including sealing washers, storm washers and load distributors) must be added together. It should be noted that the sealing washer thickness for screws with a pre-assembled sealing washer is already taken into account when specifying the clamping thickness.

The component thicknesses from the respective technical approvals and assessments must be observed!

If you have any questions about the selection of the suitable screw length for your application, please contact our application technology department.

## Drilling capacity

The drilling capacity refers to the drill point of a screw. The value is calculated from the thickness of the components to be drilled. A drilling capacity of 6 mm, for instance, means that the drill point can penetrate components with a maximum thickness of 6 mm.

The following formulas can be used to determine the required drilling capacity:

### Drilling capacity for direct bearing surface

(trapezoidal profile to steel substructure):

$$t = \text{component } t_I + \text{component } t_{II}$$

(Fig. 2)

### Drilling capacity for sandwich panel:

$$t = \text{component } t_{II}$$

(Fig. 3)

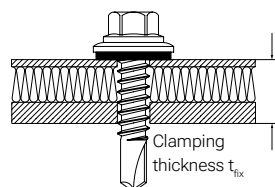

Fig. 1

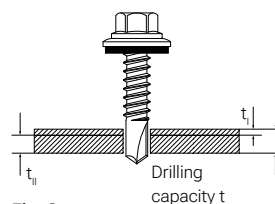

Fig. 2

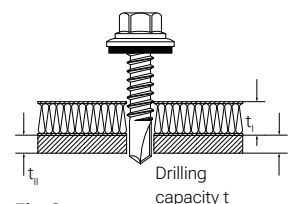
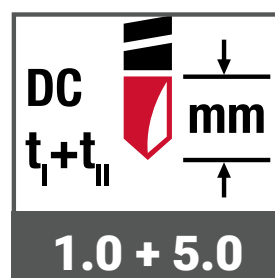

Fig. 3



Icon for specifying the drilling capacity of a self-drilling screw

# Self-drilling screws with free spin zone

Permanently reliable connection of profiled panels

**According to the current IFBS assembly guidelines, screws with a so-called free spin zone should be used for side lap stitching of metal profile panels or for attaching flashings.**

The free spin zone is a non-threaded area underneath the screw head. This minimises the risk of possible stripping of the sheets, which would result in a loss of load-carrying capacity. In addition, it offers turning-back protection, which prevents unintentional loosening of the screw and thus a loss of tightness of the roof.

Example side lap stitching: Both profiled panels are drilled one after the other and pulled towards the screw head. During this process, the sheets "lock"; this means a gap is created between component I and component II. If screws without free spin zone are used, the first sheet may be stripped when trying to pull the two sheets together. It is also possible to strip the second sheet if the screw is rotated further; this would considerably reduce the load-carrying capacity of the connection. If screws with a free spin zone are used instead, both sheets will be positioned neatly under the screw head after assembly.

## Maximum protection due to special shape of the free spin zone

On industrial roofs, the profiled panels of the cover shell are exposed to particularly strong weather influences. Due to the interplay of heat and cold, the sheets experience a strong linear expansion. This can lead to loosening of the side lap stitching if the screws are forced out of the sheets over time. The consequence: possible damage due to the side laps opening up and moisture penetration. Therefore, EJOT recommends to use screws with a special shape of the free spin zone, such as the side lap screw EJOFAST® JF3-2H-4.8.

Important: This is a geometric change in the fastener shank diameter, in which the shank is smaller than or equal to the thread core diameter. This special shape of the free spin zone prevents unintended turning back of the screw.

## Short-term "tacking" or permanent connection?

What to do when screws are only used for so-called "tacking" and then have to be loosened again? If profiled panels are only to be connected for a short time in order to be able to align them better on the roof, the safety-relevant advantages of a self-drilling screw with free spin zone are not necessary. In this case, screws without free spin zone can be used, such as the EJOFAST® JF3-2-5.5.



Screw EJOFAST® JF3-2H-4.8 with geometrically modified free spin zone according to IFBS assembly guidelines.

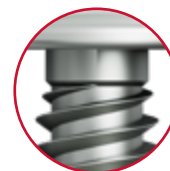

Screw with simple non-threaded part.



Screw EJOFAST® JF3-2-5.5 without free spin zone.

# Corrosion protection

For the correct selection of mechanical fasteners, it is essential to consider the exposure to corrosion when installed. This is adversely affected, amongst other things, by air pollutants such as sulfur dioxide or salty atmospheres in coastal areas.

But even factors such as humidity can lead to corrosion on screws and fasteners with insufficient surface coating or wrong choice of materials and thus permanently damage the connection.

## Corrosivity categories

In order to determine the existing exposure to corrosion, the DIN EN ISO 12944-2 classifies the atmospheric environmental conditions into the adjacent six corrosivity categories.

Category	Explanation	Example
C1	insignificant	Heated buildings with neutral atmosphere
C2	low	Rural areas, unheated buildings
C3	moderate	Urban and industrial areas
C4	high	Industrial and coastal areas
C5	very high	Industrial areas with high humidity and aggressive atmosphere, coastal atmosphere with high salt pollution
CX	extreme	Industrial areas with extreme humidity and aggressive atmosphere; subtropical and tropical atmosphere; offshore areas

For environmental conditions  $\geq$  C2, the European Technical Assessments ETA-10/0200 and ETA-13/0177 demand the usage of fastening elements made of stainless steel. For mechanical fastening, further suitable measures to avoid galvanic corrosion between the individual components and between the components and the fastening element have to be taken.

## Stainless steel

The expression stainless steel comprises steel alloys with a considerably improved corrosion resistance compared to non-alloy steels. A minimum of 10.5% chromium content by mass is typical for these stainless steels. According to the DIN EN ISO 3506, mechanical fasteners can be produced from grade A2 or A4 stainless steels.

Whereas A2 stainless steel fasteners are suitable for minimal and moderate exposures to corrosion, grade A4 stainless steels are required in areas with high exposure to corrosion. For applications with a very high exposure to corrosion, EJOT recommends the usage of fastening elements made of A8 stainless steel (High Corrosion Resistant - HRC). According to the German general building authorities approval Z-30.3-6, this material is assigned to the highest corrosion resistance category V.



**Micrograph**

500 times magnification

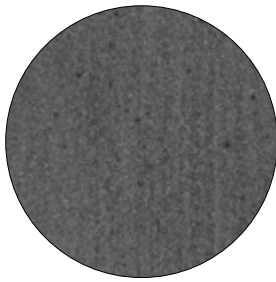

**Carbon steel**

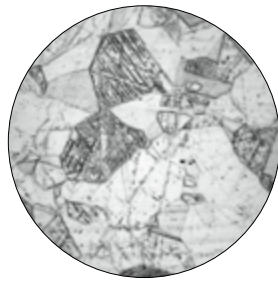

**A2 stainless steel**  
1.4301

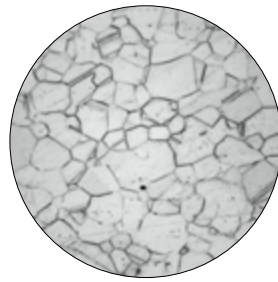

**A4 stainless steel**  
1.4401

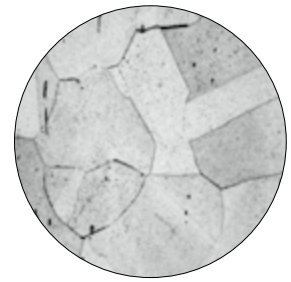

**A8 stainless steel**  
1.4529

**Zinc-plated**

Zinc-plated steel screws are used in environments with insignificant exposures to corrosion such as indoor areas of heated buildings. The galvanisation only slightly increases the corrosion resistance of the fasteners. Concerning JT3 bi-met self-drilling screws, the galvanic zinc plating shall protect the drill point from corrosion during transport and storage. Furthermore, galvanic zinc layers serve as a functional layer to improve the installation parameters of self-drilling and self-tapping screws.

**EJOGUARD**

Thanks to the combination of specifically concerted coatings, the EJOGUARD surface offers excellent corrosion properties. With a salt spray test resistance of one thousand hours according to DIN EN ISO 9227 and 15 Kesternich cycles according to DIN 50018, the application range of steel screws is significantly expanded, depending on national regulations. In Germany, self-drilling screws with EJOGUARD coating can only be used in environments with insignificant corrosion exposure, such as indoors.

**Multiple protection EJOGUARD:**

- 1** Carbon steel
- 2** Zinc coating
- 3** Organic coating
- 4** Additional sealant

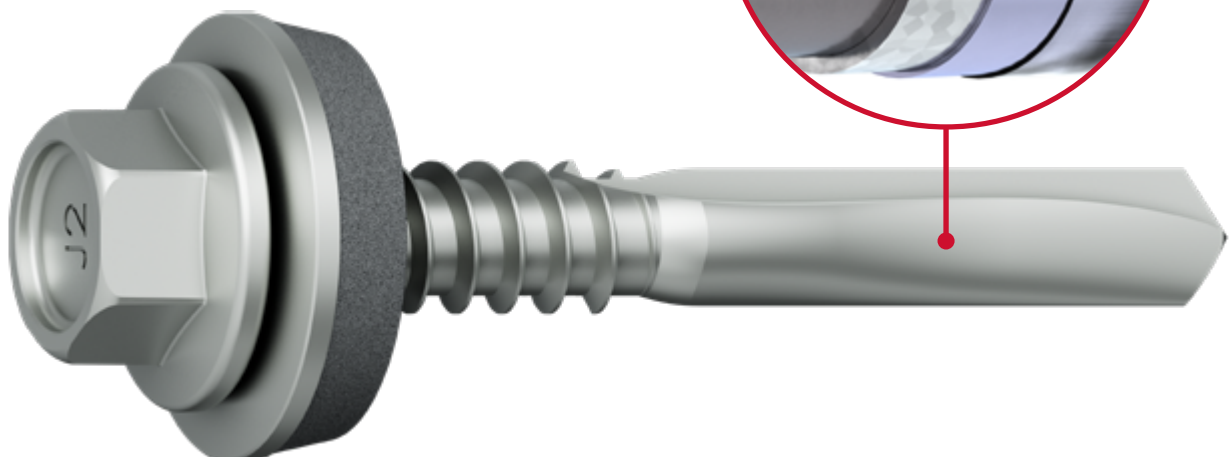
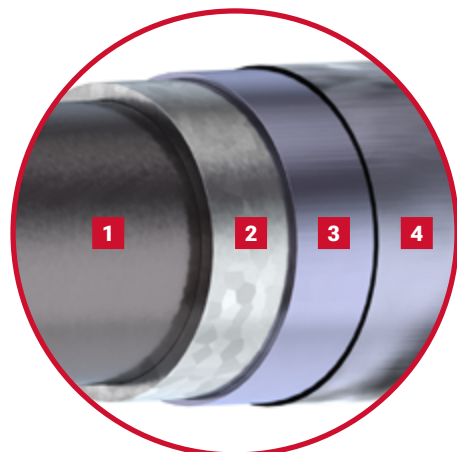

# Advice for screw installation

## Installation depth into timber

For trapezoidal profile fastenings, the installation depth into timber is regulated by the respective approval. The minimum installation depth of a 6.8 screw is 27.2 mm. The maximum installation depth, which may still be used mathematically, equals the thread length.

For fastening a 0.75 mm trapezoidal steel profile with a 6.8 screw into timber, an installation depth of 50 mm has proven to be optimal in practical experience. The force ratio between the pull-out capacity and pullover load is then more or less balanced.

## Pre-drilling in timber

Pre-drilling may be omitted if a self-drilling screw is used. The no-swarf EJOFAST® screws for timber can also be used without pre-drilling. Pre-drilling of timber has the advantage that expansion forces, which can lead to splicing of the wood, can be clearly reduced.

## Side lap stitching

If side lap stitching is not regulated any differently, it has to be spaced 500 - 666 mm apart, according to DIN EN 1090. A screw spacing of 500 to 600 mm has

proven to be very practical. In the water-bearing surface (outdoor area), the screw spacing may only be a maximum of 500 mm according to IFBS.

## Note on screw length

For countersunk screws (countersunk heads), the head is added to the screw length. For screws with surface mounted heads the screw length is measured to below the head.

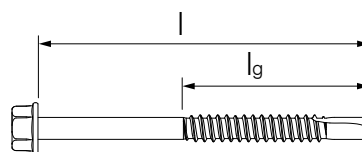

**Fig. 1**  
Hexagon head screw with drill point

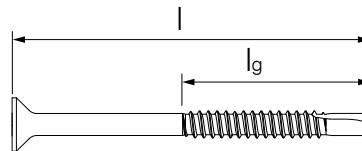

**Fig. 2**  
Countersunk screw with drill point

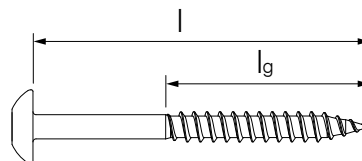

**Fig. 3**  
Truss head screw with JF point

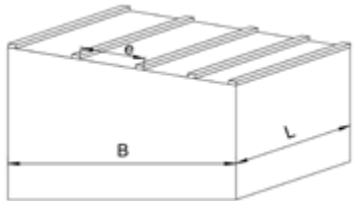
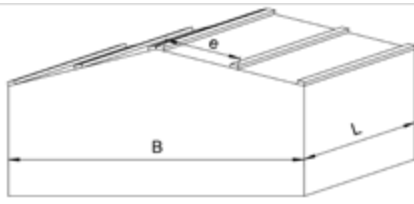
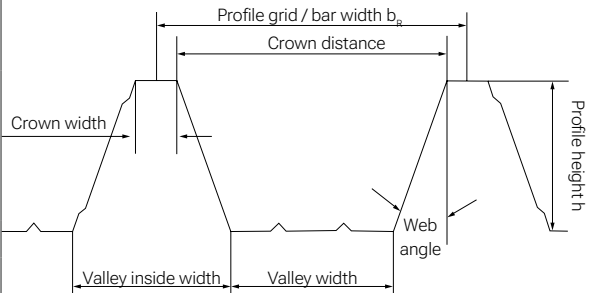
Pent roof, flat roof	Gable roof
	
<p><b>Description</b></p> 	<p><b>Number of fastening screws (pent roof, flat roof)</b></p> $N_1 = \left( \left( \frac{B}{e} + 3 \right) \cdot \frac{L}{2 \cdot b_R} \right) \text{ or } N = \left( \frac{L \cdot B}{2 \cdot e \cdot b_R} + \frac{3L}{2 \cdot b_R} \right) \cdot 1.2 \cdot N$
	<p><b>Number of fastening screws (gable roof)</b></p> $N_1 = \left( \left( \frac{B}{e} + 5 \right) \cdot \frac{L}{2 \cdot b_R} \right) \text{ or } N = \left( \frac{L \cdot B}{2 \cdot e \cdot b_R} + \frac{5L}{2 \cdot b_R} \right) \cdot 1.2 \cdot N$
<p><b>Number of side lap screws</b></p> <p><math>N_2 = \text{roof or wall area respectively [m}^2\text{]} \cdot 2.2 + (\text{building length [m]} + [\text{building width [m]}]) \cdot 6</math></p>	

EJOT recommends the use of screws with a free spin zone in order to prevent stripping of the screws and a destruction of the sealing washers.

### Determination of the screw lengths

To determine the correct screw length, the clamping thickness of the respective screw must be considered. The components are clamped in this area (absorption and transfer of forces and loads in accordance with the respective technical approvals and assessments).

The required clamping thickness of a screw is calculated from the material thickness of the components to be clamped. For this, the thicknesses of components I and II, any intermediate layer and additional elements (including sealing washers, storm washers and load distributors) must be added together.

To determine the screw length, please refer to **page 22 and 83** and the information in the tables on the product-specific pages.

| see page 22 and 83

### EJOT recommends ORKAN storm washers

Special attention should be paid to the waterproofing of fastening elements. Practical experience has shown that leakage of only a few tenth millimetres can lead to considerable damage. For that reason EJOT recommends crown fixing with storm washers. ORKAN storm washers prevent an indentation of the crown and provide a very high degree of safety against rainwater penetration.

### Quantity determination

For a rough estimate of the fastener quantity it can be assumed that an average of approx.

**2 fastening screws and  
3 side lap screws per m<sup>2</sup> steep roof are required.**

**The IFBS regulations must be observed.**

### EJOT recommends using sealing washers - also in combination with case-hardened steel screws that are used in unweathered areas.

The risk of damaging the screw joint due to incorrect installation (e.g. excessive tightening torque, slightly sloped clamping) is significantly reduced when using sealing washers. Furthermore, the clamp load and thus the tensile stress in the screw are limited by the use of sealing washers. Direct weathering of the drill hole, in which the surface protection layers are perforated by the screwing process, is prevented by the sealing washers. The risk of operation-related, hydrogen-induced brittle fracture is significantly reduced.

### Rain-proof connections

The use of sealing washers facilitates the formation of rain-proof fastening and connection points in lightweight metal construction.

When planning and executing the connections, the minimum roof pitches according to the specialist rules for lightweight metal construction must be observed.

### Correct installation of sealing washers

Screws with sealing washers must be installed using a depth stop. Impermissible deformation of the sealing washer (washer with elastomer seal) is prevented with the adjustable depth stop on the screwdriver. If the sealing washer is correctly installed, the rubber seal may overlap. Only if the metal back of the sealing washer changes from convex to concave, the joint is definitely too tight.

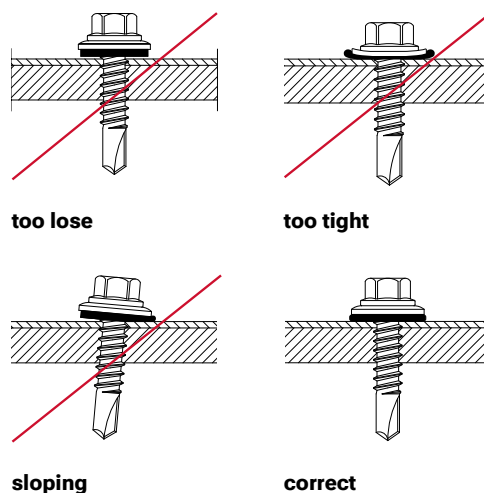

## EJOFAST® self-drilling screw JF2-2H-4.8



### Application range

- > Side lap stitching of profiled steel sheets

### Properties

- > Case-hardened steel, protected against corrosion
- > Fastening with reduced swarf
- > With free spin zone under screw head for side lap stitching
- > Non-skid application
- > Suitable for installation with the EJOFAST® JF screwdriver

Cross references	Page
Cordless screwdriver	
ASCM QSW	135
Socket wrench insert SW8	141



## EJOFAST

### Applications

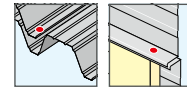

### Technical specifications

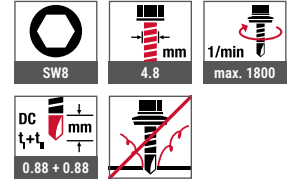

### Certifications

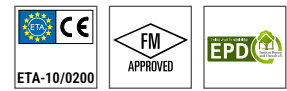

### Assembly instruction



### Product in the online shop



**EJOFAST® JF screwdriver**  
Rental equipment available  
Article number G00000070

Order description	Length [mm]	Clamping thickness [mm]	PU [pieces]	Price/100 [EUR]	Article number	EAN
<b>loose</b>						
JF2-2H-4.8x19	19	0 - 9	1000		7280628601	4061245014524
JF2-2H-4.8x19 VE100	19	0 - 9	100		6280628601	4061245014890
<b>Collated</b>						
JF2-2H-4.8x19 collated	19	0 - 9	500		3375000000	4061245016573

## Self-drilling screw JT2-2H-4.8 EJOGUARD



Cross references	Page
Cordless screwdriver	
ASCM QSW	135
Socket wrench insert SW8	141

### Application range

- > Side lap stitching of profiled steel sheets

### Properties

- > Case-hardened steel, protected against corrosion
- > With free spin zone under screw head for effective side lap stitching

### Applications

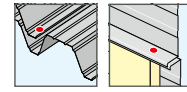

### Technical specifications

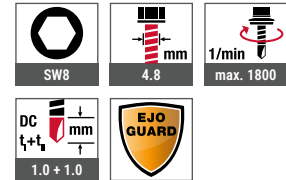

### Certifications

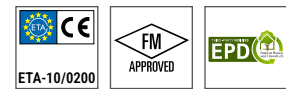

### Assembly instruction



### Product in the online shop



Order description	Length [mm]	Clamping thickness [mm]	PU [pieces]	Price/100 [EUR]	Article number	EAN
JT2-2H-4.8x19 EJOGUARD	19	0 - 9	1000		3592200997	4061245093062
JT2-2H-4.8x19 EJOGUARD VE100	19	0 - 9	100		6592200997	4061245093079

## Self-drilling screw JT2-3-4.8 EJOGUARD



### Application range

- > Fastening profiled steel sheets to 2 mm steel substructure
- > Side lap stitching of profiled steel sheets
- > Suitable for installation with the EJOFAST® JF screwdriver

### Properties

- > Case-hardened steel, protected against corrosion
- > Loose or collated

### Cross references

Cross references	Page
Cordless screwdriver	
ASCM QSW	135
Socket wrench insert SW8	141

### Assembly instruction



### Product in the online shop



**EJOFAST® JF screwdriver**  
Rental equipment available  
Article number G000000070

### Applications

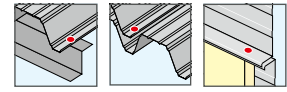

### Technical specifications

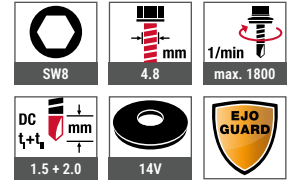

### Certifications

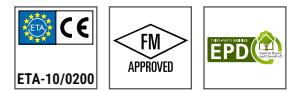

Order description	Length [mm]	Clamping thickness [mm]	PU [pieces]	Price/100 [EUR]	Article number	EAN
<b>Loose</b>						
JT2-3-4.8x19 EJOGUARD	19	0 - 11	1000		3592200614	4061245093918
JT2-3-4.8x19 EJOGUARD VE100	19	0 - 11	100		6592200614	4061245092904
<b>Collated</b>						
JT2-3-4.8x19 EJOGUARD collated	19	0 - 11	500		3365100000	4061245092928
<b>Sealing washer V14, Ø 14 mm</b>						
JT2-3-4.8x19 V14 EJOGUARD	19	0 - 9	500		3592251614	4061245092966

## Self-drilling screw JT2-2H-Plus-5.5 F12 EJOGUARD



Cross references	Page
Cordless screwdriver	
ASCM QSW	135
Socket wrench insert SW8	141

### Application range

- > Side lap stitching of profiled steel sheets
- > Fastening profiled steel sheets to 0.4–2.0 mm steel substructure
- > For high-strength steel substructures according to ETA-21/0420

### Properties

- > Case-hardened steel, protected against corrosion
- > Steel sealing washer, zinc-plated
- > Pre-assembled sealing washer
- > With free spin zone under screw head for effective side lap stitching

### Applications

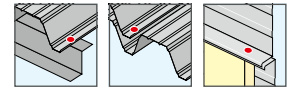

### Technical specifications

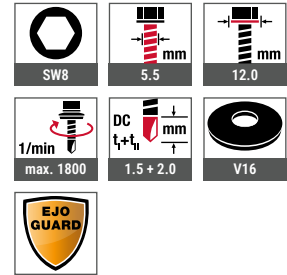

### Certifications



### Assembly instruction



### Product in the online shop



Order description	Length [mm]	Clamping thickness [mm]	PU [pieces]	Price/100 [EUR]	Article number	EAN
<b>Sealing washer V16, Ø 16 mm</b>						
JT2-2H-Plus-5.5x25 F12 V16 EJOGUARD	25	0 – 9	500		3512521997	4061245092980

## Self-drilling screw JT2-6-5.5 F12 EJOGUARD



### Application range

- > Fastening profiled steel sheets to 1.5–4 mm steel substructure
- > For high-strength steel substructures according to ETA-21/0420

### Properties

- > Case-hardened steel, protected against corrosion
- > Steel sealing washer, zinc-plated
- > Pre-assembled sealing washer

### Applications

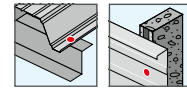

### Technical specifications

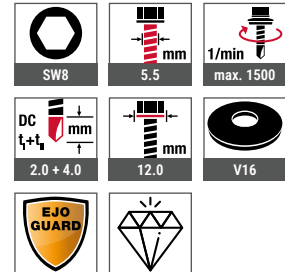

### Cross references

	Page
Cordless screwdriver	
ASCM QSW	135
Socket wrench insert SW8	141

### Assembly instruction



### Product in the online shop



### Certifications



Order description	Length [mm]	Clamping thickness [mm]	PU [pieces]	Price/100 [EUR]	Article number	EAN
<b>Sealing washer V16, Ø 16 mm</b>						
JT2-6-5.5X20 F12 V16 EJOGUARD	20	0 – 5	500		3973321634	4061245092706
JT2-6-5.5X25 F12 V16 EJOGUARD	25	0 – 10	500		3973421634	4061245105741
JT2-6-5.5X25 F12 V16 EJOGUARD VE100	25	0 – 10	100		6973421634	4061245092935

## Self-drilling screw JT2-6-6.3 F12 EJOGUARD

**Application range**

- > Fastening profiled steel sheets to 2–5 mm steel substructure

**Properties**

- > Case-hardened steel, protected against corrosion
- > Steel sealing washer, zinc-plated
- > Pre-assembled sealing washer

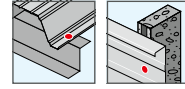
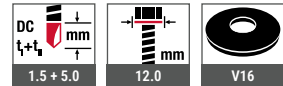
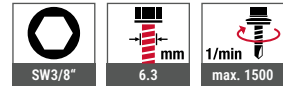
**Applications****Technical specifications****Cross references**

Cross references	Page
Cordless screwdriver	
ASCM QSW	135
Socket wrench insert SW3/8"	141

**Certifications****Assembly instruction****Product in the online shop**

Order description	Length [mm]	Clamping thickness [mm]	PU [pieces]	Price/100 [EUR]	Article number	EAN
<b>Sealing washer V16, Ø 16 mm</b>						
JT2-6-6.3X22 F12 V16 EJOGUARD	22	0 – 7	500		3824221997	4061245092942
JT2-6-6.3X25 F12 V16 EJOGUARD	25	0 – 10	500		3824421997	4061245092515
JT2-6-6.3X25 F12 V16 EJOGUARD VE100	25	0 – 10	100		6824421997	4061245092959
JT2-6-6.3X32 F12 V16 EJOGUARD	32	0 – 17	500		3824321997	4061245092522
JT2-6-6.3X38 F12 V16 EJOGUARD	38	0 – 23	500		3824521997	4061245092539

## Self-drilling screw JT2-12-5.5 F12 EJOGUARD



### Application range

- > Fastening profiled steel sheets to 4–10 mm steel substructure

### Properties

- > Case-hardened steel, protected against corrosion
- > High-grade coating to improve the corrosion protection
- > Steel sealing washer, zinc-plated
- > Pre-assembled sealing washer

### Applications

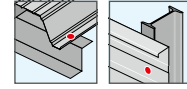

### Technical specifications

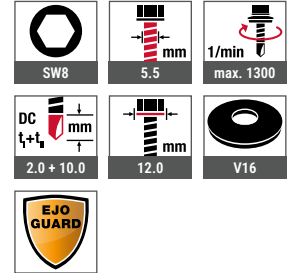

### Certifications



Cross references	Page
Cordless screwdriver	
ASCM QSW	135
Socket wrench insert SW8	141

### Assembly instruction



### Product in the online shop



Order description	Length [mm]	Clamping thickness [mm]	PU [pieces]	Price/100 [EUR]	Article number	EAN
<b>Sealing washer V16, Ø 16 mm</b>						
JT2-12-5.5X35 F12 V16 EJOGUARD	35	0 – 10	500		3814521997	4061245092546
JT2-12-5.5X35 F12 V16 EJOGUARD VE100	35	0 – 10	100		6814521997	4061245092553
JT2-12-5.5X50 F12 V16 EJOGUARD	50	0 – 25	250		3817121997	4061245092560
JT2-12-5.5X50 F12 V16 EJOGUARD VE100	50	0 – 25	100		6817121997	4061245092577
JT2-12-5.5X65 F12 V16 EJOGUARD	65	6 – 40	250		3817521997	4061245092584
JT2-12-5.5X65 F12 V16 EJOGUARD VE100	65	6 – 40	100		6817521997	4061245092607

## Self-drilling screw JT2-18-5.5 F12 EJOGUARD



### Application range

- > Fastening profiled steel sheets to 4–16 mm steel substructure

### Properties

- > Case-hardened steel, protected against corrosion
- > High-grade coating to improve the corrosion protection
- > Steel sealing washer, zinc-plated
- > Pre-assembled sealing washer

### Applications

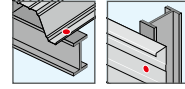

### Technical specifications

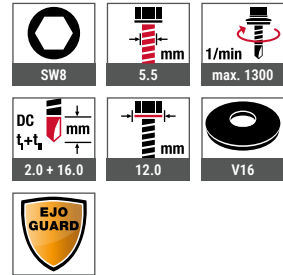

Cross references	Page
Cordless screwdriver	
ASCM QSW	135
Socket wrench insert SW8	141

### Certifications



### Assembly instruction



### Product in the online shop



Order description	Length [mm]	Clamping thickness [mm]	PU [pieces]	Price/100 [EUR]	Article number	EAN
<b>Sealing washer V16, Ø 16 mm</b>						
JT2-18-5.5x40 F12 V16 EJOGUARD	40	0 – 12	500		3914021997	4061245014913

## Self-drilling screw JT2-FZ-6-6.3 EJOGUARD



### Application range

- > Fastening corrugated fibre cement sheet to steel substructure 1.5–5 mm

### Properties

- > Case-hardened steel, protected against corrosion
- > Fibre cement seal FZD pre-assembled
- > A2 stainless steel washer
- > Screw wings save additional drilling into the corrugated slabs
- > Reduced forcing tension

### Notice

For the dimensioning and the use of fastening materials please note the manufacturer's instructions for use as well as the national approvals.

### Applications



### Technical specifications

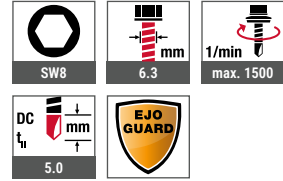

### Certifications



Cross references	Page
Cordless screwdriver	
ASCM QSW	135
Socket wrench insert SW8	141

### Assembly instruction



### Product in the online shop



Order description	Length [mm]	PU [pieces]	Price/100 [EUR]	Article number	EAN
JT2-FZ-6-6.3x110 FZD EJOGUARD	110	100		3512275664	4061245016092

## Self-drilling screw JT2-FZ-12-6.3 EJOGUARD



Cross references	Page
Cordless screwdriver	
ASCM QSW	135
Socket wrench insert SW8	141

**Application range**

- > Fastening corrugated fibre cement sheet to steel substructure 5–12 mm

**Properties**

- > Case-hardened steel, protected against corrosion
- > Fibre cement seal FZD pre-assembled
- > A2 stainless steel washer
- > Screw wings save additional drilling into the corrugated slabs
- > Reduced forcing tension

**Notice**

For the dimensioning and the use of fastening materials please note the manufacturer's instructions for use as well as the national approvals.

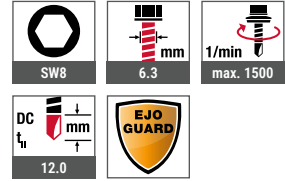
**Applications****Technical specifications****Certifications****Assembly instruction****Product in the online shop**

Order description	Length [mm]	PU [pieces]	Price/100 [EUR]	Article number	EAN
JT2-FZ-12-6.3x115 FZD EJOGUARD	115	100		3512375614	4061245016085

## Self-drilling screw JT2-FZ-F-6.5



### Application range

- > Fastening corrugated fibre cement sheets to timber substructure

### Properties

- > Case-hardened steel, hot-dip zinc-plated
- > Fibre cement seal FZD pre-assembled
- > A2 stainless steel washer
- > Screw wings save additional drilling into the corrugated slabs
- > Reduced forcing tension

### Notice

For the dimensioning and the use of fastening materials please note the manufacturer's instructions for use as well as the national approvals.

### Applications



### Technical specifications

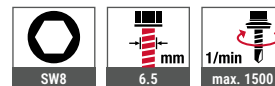

### Certifications



Cross references	Page
JT4-FZ-6.5x130 FZD	77
Cordless screwdriver	
ASCM QSW	135
Socket wrench insert SW8	141

### Assembly instruction



### Product in the online shop



Order description	Length [mm]	Thread length [mm]	PU [pieces]	Price/100 [EUR]	Article number	EAN
JT2-FZ-F-6.5x100 FZD*	100	50	100		3515175608	4061245016078
JT2-FZ-F-6.5x130 FZD*	130	50	100		3515675608	4061245016054

\*No approval

## Self-drilling screw JT2-ST-2-6.0 EJOGUARD



Cross references	Page
Cordless screwdriver	
ASCM QSW	135
Bit hexalobular TX25	142
Bit holder	143

## Application range

- > Fastening timber components to thin-walled steel substructures
- > Fastening of edge planks
- > To fix roofing membranes and insulating material to substructures made of sheet steel  $\geq 0.70$  in mm  $\leq 1.5$  mm, timber or wood-based material in combination with EJOT stress plates

## Properties

- > Case-hardened steel, protected against corrosion
- > With countersunk head

## Applications

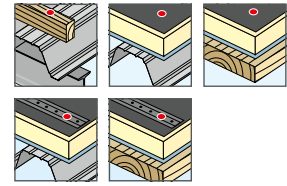

## Technical specifications

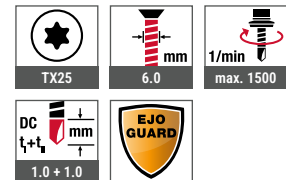

## Certifications

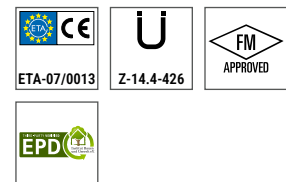

## Assembly instruction



## Product in the online shop



Order description	Length [mm]	Thread length [mm]	Clamping thickness [mm]	PU [pieces]	Price/100 [EUR]	Article number	EAN
JT2-ST-2-6.0x40 EJOGUARD	40	40	0 – 27	500		7282110609	4061245014517
JT2-ST-2-6.0x60 EJOGUARD	60	45	15 – 47	500		7282119609	4061245014432
JT2-ST-2-6.0x80 EJOGUARD	80	65	15 – 67	250		7282112609	4061245014500
JT2-ST-2-6.0x100 EJOGUARD	100	65	35 – 87	250		7282113609	4061245014494
JT2-ST-2-6.0x120 EJOGUARD	120	65	55 – 107	250		7282114609	4061245014487
JT2-ST-2-6.0x140 EJOGUARD	140	65	75 – 127	250		7282115609	4061245014470
JT2-ST-2-6.0x160 EJOGUARD	160	65	95 – 147	100		7282116609	4061245014463
JT2-ST-2-6.0x180 EJOGUARD	180	65	115 – 167	100		7282117609	4061245014456
JT2-ST-2-6.0x200 EJOGUARD	200	65	135 – 197	100		7282118609	4061245014449

## Self-drilling screw JT2-ST-2-6.8 EJOGUARD



### Application range

- > Fastening milled system rails to thin-walled steel and aluminium substructures
- > To fix roofing membranes and insulating material to substructures made of sheet steel  $\geq 0.70$  in mm  $\leq 1.5$  mm, timber or wood-based material in combination with EJOT stress plates

### Properties

- > Case-hardened steel, protected against corrosion
- > EJOGUARD corrosion protection
- > With countersunk head

### Applications

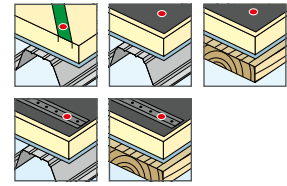

### Technical specifications

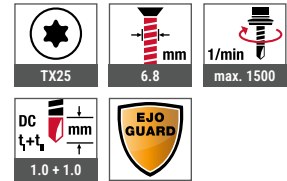

### Certifications

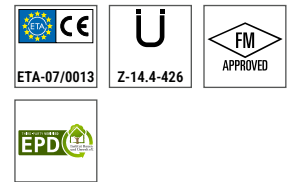

Cross references	Page
Cordless screwdriver	
ASCM QSW	135
Bit hexalobular TX25	142
Bit holder	143

### Assembly instruction



### Product in the online shop



Order description	Length [mm]	Thread length [mm]	Clamping thickness [mm]	PU [pieces]	Price/100 [EUR]	Article number	EAN
JT2-ST-2-6.8x205 EJOGUARD	205	75	130 - 195	100		7282305609	4061245014425
JT2-ST-2-6.8x245 EJOGUARD	245	75	170 - 235	100		7282345609	4061245014401
JT2-ST-2-6.8x285 EJOGUARD	285	75	210 - 275	100		7282385609	4061245014395
JT2-ST-2-6.8x325 EJOGUARD	325	75	250 - 315	100		7282335609	4061245014418

## Self-drilling screw JT2-WD-5-5.5



### Application range

- > Special screw for fastening wood to steel substructures up to a thickness of 5 mm

### Properties

- > Case-hardened steel, protected against corrosion
- > The wings widen the drill hole in the wood component to be fastened in order to prevent forced feed. They break off as soon as they touch the steel substructure. This prevents the wood to be fastened from being pushed away from the substructure.

### Notice

To ensure shearing of the wings, the material thickness of the steel substructure must be at least 2.5 mm. The screw is not suitable for fastening OSB boards.

### Applications



### Technical specifications

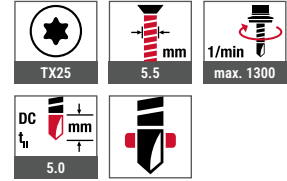

Cross references	Page
Cordless screwdriver	
ASCM QSW	135
Bit hexalobular TX25	142
Bit holder	143

### Assembly instruction



### Product in the online shop



Order description	Length [mm]	Thread length [mm]	Clamping thickness [mm]	PU [pieces]	Price/100 [EUR]	Article number	EAN
JT2-WD-5-5.5x50	50	30	12 – 35	200		7289206601	4061245014388
JT2-WD-5-5.5x60	60	30	22 – 45	200		7289207601	4061245014371
JT2-WD-5-5.5x80	80	60	12 – 65	200		7289208601	4061245014364
JT2-WD-5-5.5x100	100	60	32 – 85	200		7289202601	4061245038537

Further lengths upon request



## EJOFAST® self-drilling screw JF3-2H-4.8



Cross references	Page
Cordless screwdriver	
ASCM QSW	135
Socket wrench insert SW8	141

### Application range

- > Side lap stitching of profiled steel / aluminium sheets and sandwich panels

### Properties

- > A2 stainless steel with hardened steel point
- > Stainless steel sealing washer
- > Pre-assembled sealing washer
- > With free spin zone under screw head for effective side lap stitching
- > Non-skid application
- > Fastening with reduced swarf
- > Loose or collated
- > Suitable for installation with the EJOFast® JF screwdriver

### Assembly instruction



### Product in the online shop



**EJOFast® JF screwdriver**  
Rental equipment available  
Article number G000000070

## EJOFAST

### Applications

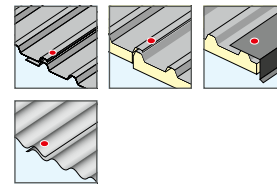

### Technical specifications

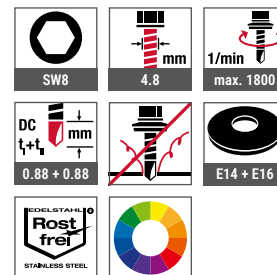

### Certifications

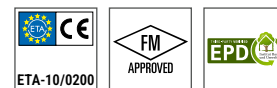

Order description	Length [mm]	Clamping thickness [mm]	PU [pieces]	Price/100 [EUR]	Article number	EAN
<b>Sealing washer E 14, Ø 14 mm, loose</b>						
JF3-2H-4.8x19 E14	19	0 - 4	500		3591977391	4061245015583
JF3-2H-4.8x19 E14 VE100	19	0 - 4	100		6591977391	4061245014791
JF3-2H-4.8x19-E14 RAL 7016	19	0 - 4	100		3351977025	4061245039749
JF3-2H-4.8x19-E14 RAL 9002	19	0 - 4	100		3351977082	4061245039671
JF3-2H-4.8x19-E14 RAL 9006	19	0 - 4	100		3351977084	4061245044804
JF3-2H-4.8x19-E14 RAL 9007	19	0 - 4	100		3351977220	4061245044811
<b>Sealing washer E 14, Ø 14 mm, collated</b>						
JF3-2H-4.8x19 E14 collated	19	0 - 4	500		3385009000	4061245016559
<b>Sealing washer E 16, Ø 16 mm, loose</b>						
JF3-2H-4.8x19 E16	19	0 - 4	500		3591911391	4061245026466

## EJOFAST® self-drilling screw JF3-FR-2-5.5



Cross references	Page
Cordless screwdriver	
ASCM QSW	135
Bit hexalobular TX25	142
FR-tool	143
FR-tool plastic	144

### Application range

- > Fixing cant parts to profiled elements

### Properties

- > A2 stainless steel with hardened steel point
- > Stainless steel sealing washer
- > Pre-assembled sealing washer
- > Non-skid application
- > Fastening with reduced swarf
- > High load-bearing capacity
- > With truss head

## EJOFAST

### Applications



### Technical specifications

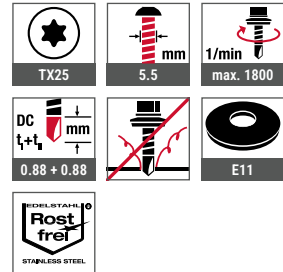

### Certifications

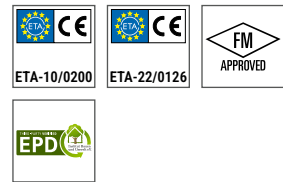

### Assembly instruction



### Product in the online shop



Order description	Length [mm]	Clamping thickness [mm]	PU [pieces]	Price/100 [EUR]	Article number	EAN
<b>Sealing washer E 11, Ø 11 mm</b>						
JF3-FR-2-5.5x25 E11	25	0 - 7	500		3593292391	4061245015460

Further versions available



Self-drilling screw JT3-2-5.5

A4 stainless steel available upon request



Self-drilling screw JF6-FR-2-5.5

**EJOFAST® self-drilling screw JF3-Plus-4.9**



**Application range**

- > Fastening profiled steel or aluminium sheets and roofing sheet to timber substructures

**Properties**

- > A2 stainless steel with hardened steel point
- > Stainless steel sealing washer
- > Pre-assembled sealing washer
- > Fastening with reduced swarf
- > Assembly without pre-drilling
- > Non-skid application
- > High load-bearing capacity

**Cross references** **Page**

ORKAN storm washers	95
Cordless screwdriver	
ASCM QSW	135
Socket wrench insert SW8	141

**Assembly instruction**



**Product in the online shop**



**EJOFAST**

**Applications**

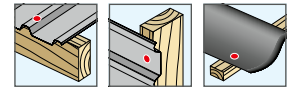

**Technical specifications**

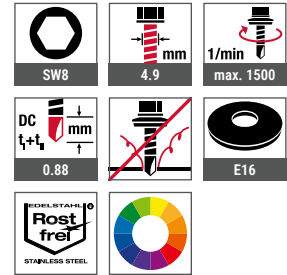

**Certifications**



Order description	Length [mm]	Thread length [mm]	Height component I [mm]	PU [pieces]	Price/100 [EUR]	Article number	EAN
<b>Sealing washer E 16, Ø 16 mm</b>							
JF3-Plus-4.9x35 E16	35	28	0 – 5	500		3593667323	4061245083605
JF3-Plus-4.9x35 E16 VE100	35	28	0 – 5	100		6593667323	4061245083506
JF3-Plus-4.9x35 E16 RAL 7016	35	28	0 – 5	100		3333667025	4061245116303
JF3-Plus-4.9x35 E16 RAL 9002	35	28	0 – 5	100		3333667082	4061245116310
JF3-Plus-4.9x35 E16 RAL 9006	35	28	0 – 5	100		3333667084	4061245116327
JF3-Plus-4.9x35 E16 RAL 9007	35	28	0 – 5	100		3333667220	4061245116334
JF3-Plus-4.9x70 E16	70	50	20 – 40	250		3597167323	4061245083612

## EJOFAST® self-drilling screw JF3-FR-plus-4.9



### Application range

- > Fastening profiled steel or aluminium sheets to timber sub-structures

### Properties

- > A2 stainless steel with hardened steel point
- > Stainless steel sealing washer
- > Pre-assembled sealing washer
- > Fastening with reduced swarf
- > Assembly without pre-drilling
- > Non-skid application
- > High load-bearing capacity
- > With truss head

### Cross references

	Page
Cordless screwdriver	
ASCM QSW	135
FR-tool	143
FR-tool plastic	144

## EJOFAST

### Applications



### Technical specifications

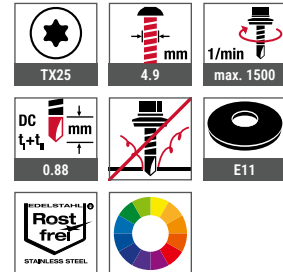

### Certifications



### Assembly instruction



### Product in the online shop



Order description	Length [mm]	Thread length [mm]	Height component I [mm]	PU [pieces]	Price/100 [EUR]	Article number	EAN
<b>Sealing washer E 11, Ø 11 mm</b>							
JF3-FR-Plus-4.9x35 E11	35	28	0 – 5	500		3593692329	4061245083629
JF3-FR-Plus-4.9x35 E11 VE100	35	28	0 – 5	100		6593692329	4061245083636
JF3-FR-Plus-4.9x35 E11 RAL 7016	35	28	0 – 5	100		3333692025	4061245116341
JF3-FR-Plus-4.9x35 E11 RAL 9002	35	28	0 – 5	100		3333692082	4061245116358
JF3-FR-Plus-4.9x35 E11 RAL 9006	35	28	0 – 5	100		3333692084	4061245116365
JF3-FR-Plus-4.9x35 E11 RAL 9007	35	28	0 – 5	100		3333692220	4061245116372

## EJOFAST® self-drilling screw JF3-Plus-6.8



### Application range

- > Fastening profiled steel and aluminium sheets and sandwich panels to timber substructures

### Properties

- > A2 stainless steel with hardened steel point
- > Stainless steel sealing washer
- > Pre-assembled sealing washer
- > Fastening with reduced swarf
- > Assembly without pre-drilling
- > Non-skid application
- > High load-bearing capacity

Cross references	Page
ORKAN storm washers	95
Cordless screwdriver	
ASCM QSW	135
Socket wrench insert SW8	141

### Assembly instruction



### Product in the online shop



## EJOFAST

### Applications

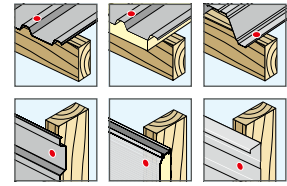

### Technical specifications

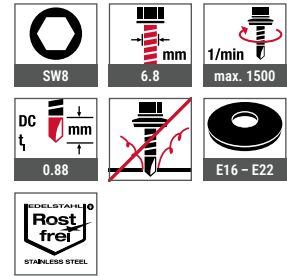

### Certifications



Order description	Length [mm]	Thread length [mm]	Height component I [mm]	PU [pieces]	Price/100 [EUR]	Article number	EAN
<b>Sealing washer E 16, Ø 16 mm</b>							
JF3-Plus-6.8x40 E16	40	40	-	250		3594067393	4061245080611
JF3-Plus-6.8x40 E16 VE100	40	40	-	100		6594067393	4061245081304
JF3-Plus-6.8x60 E16	60	60	0 - 10	250		3594167393	4061245080635
JF3-Plus-6.8x60 E16 VE100	60	60	0 - 10	100		6594167393	4061245081335
JF3-Plus-6.8x80 E16	80	75	0 - 30	250		3594267393	4061245081366
JF3-Plus-6.8x80 E16 VE100	80	75	0 - 30	100		6594267393	4061245081373
JF3-Plus-6.8x100 E16	100	75	20 - 50	100		3594367393	4061245081403
JF3-Plus-6.8x120 E16	120	75	40 - 70	100		3594467393	4061245081434
JF3-Plus-6.8x140 E16	140	75	60 - 90	100		3594567393	4061245081465
JF3-Plus-6.8x160 E16	160	75	80 - 110	100		3594667393	4061245081496
JF3-Plus-6.8x180 E16	180	75	100 - 130	100		3594767393	4061245081526
JF3-Plus-6.8x200 E16	200	75	120 - 150	100		3594867393	4061245081557
JF3-Plus-6.8x220 E16	220	75	140 - 170	100		3594967393	4061245081601
JF3-Plus-6.8x240 E16	240	75	160 - 190	100		3595067393	4061245081632
JF3-Plus-6.8x260 E16	260	75	180 - 210	100		3595167393	4061245081663
JF3-Plus-6.8x280 E16	280	75	200 - 230	100		3595267393	4061245081694
JF3-Plus-6.8x300 E16	300	75	220 - 250	100		3595367393	4061245081724





Order description	Length [mm]	Thread length [mm]	Height component I [mm]	PU [pieces]	Price/100 [EUR]	Article number	EAN
<b>Sealing washer E 19, Ø 19 mm</b>							
JF3-Plus-6.8x40 E19	40	40	-	250		3594066393	4061245081311
JF3-Plus-6.8x60 E19	60	60	0 - 10	250		3594166393	4061245081342
JF3-Plus-6.8x80 E19	80	75	0 - 30	100		3594266393	4061245081380
JF3-Plus-6.8x100 E19	100	75	20 - 50	100		3594366393	4061245081410
JF3-Plus-6.8x120 E19	120	75	40 - 70	100		3594466393	4061245081441
JF3-Plus-6.8x140 E19	140	75	60 - 90	100		3594566393	4061245081472
JF3-Plus-6.8x160 E19	160	75	80 - 110	100		3594666393	4061245081502
JF3-Plus-6.8x180 E19	180	75	100 - 130	100		3594766393	4061245081533
JF3-Plus-6.8x200 E19	200	75	120 - 150	100		3594866393	4061245081564
JF3-Plus-6.8x220 E19	220	75	140 - 170	100		3594966393	4061245081618
JF3-Plus-6.8x240 E19	240	75	160 - 190	100		3595066393	4061245081649
JF3-Plus-6.8x260 E19	260	75	180 - 210	100		3595166393	4061245081670
JF3-Plus-6.8x280 E19	280	75	200 - 230	100		3595266393	4061245081700
JF3-Plus-6.8x300 E19	300	75	220 - 250	100		3595366393	4061245081731
<b>Sealing washer E 22, Ø 22 mm</b>							
JF3-Plus-6.8x40 E22	40	40	-	250		3594013393	4061245081328
JF3-Plus-6.8x60 E22	60	60	0 - 10	250		3594113393	4061245081359
JF3-Plus-6.8x80 E22	80	75	0 - 30	100		3594213393	4061245081397
JF3-Plus-6.8x100 E22	100	75	20 - 50	100		3594313393	4061245081427
JF3-Plus-6.8x120 E22	120	75	40 - 70	100		3594413393	4061245081458
JF3-Plus-6.8x140 E22	140	75	60 - 90	100		3594513393	4061245081489
JF3-Plus-6.8x160 E22	160	75	80 - 110	100		3594613393	4061245081519
JF3-Plus-6.8x180 E22	180	75	100 - 130	100		3594713393	4061245081540
JF3-Plus-6.8x200 E22	200	75	120 - 150	100		3594813393	4061245081571
JF3-Plus-6.8x220 E22	220	75	140 - 170	100		3594913393	4061245081625
JF3-Plus-6.8x240 E22	240	75	160 - 190	100		3595013393	4061245081656
JF3-Plus-6.8x260 E22	260	75	180 - 210	100		3595113393	4061245081687
JF3-Plus-6.8x280 E22	280	75	200 - 230	100		3595213393	4061245081717
JF3-Plus-6.8x300 E22	300	75	220 - 250	100		3595313393	4061245081748
<b>*Calculated with the setting depth of 50 mm recommended by EJOT. Deviating setting depths possible according to ETA.</b>							

## Self-drilling screw JT3-2H-4.8



Cross references	Page
Cordless screwdriver	
ASCM QSW	135
Socket wrench insert SW8	141

### Application range

- > Side lap stitching of profiled steel / aluminium sheets and sandwich panels
- > Fastening of flashings

### Properties

- > Suitable for installation with the EJOFAST® JF screwdriver
- > A2 stainless steel with hardened steel drill point
- > Stainless steel sealing washer
- > Pre-assembled sealing washer
- > With free spin zone under screw head for effective side lap stitching
- > Loose or collated

### Applications

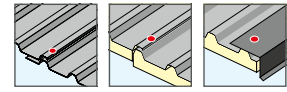

### Technical specifications

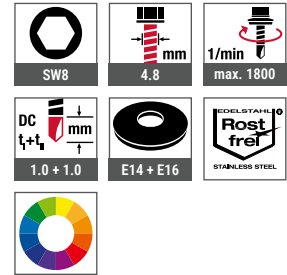

### Certifications

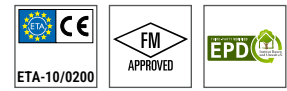

### Assembly instruction



### Product in the online shop



**EJOFAST® JF screwdriver**  
Rental equipment available  
Article number G000000070

Order description	Length [mm]	Clamping thickness [mm]	PU [pieces]	Price/100 [EUR]	Article number	EAN
<b>Sealing washer E 14, Ø 14 mm, loose</b>						
JT3-2H-4.8x19 E14	19	0 - 4	500		3591977351	4061245015590
JT3-2H-4.8x19 E14 VE100	19	0 - 4	100		6591977351	4061245014807
JT3-2H-4.8x19-E14 RAL 7016	19	0 - 4	100		3531977525	4061245035826
JT3-2H-4.8x19-E14 RAL 9002	19	0 - 4	100		3531977582	4061245035987
JT3-2H-4.8x19-E14 RAL 9006	19	0 - 4	100		3531977584	4061245036007
JT3-2H-4.8x19-E14 RAL 9007	19	0 - 4	100		3380209220	4061245036014
<b>Sealing washer E 14, Ø 14 mm, collated</b>						
JT3-2H-4.8x19 E14 collated	19	0 - 4	500		3380209000	4061245016566
<b>Sealing washer E 16, Ø 16 mm, loose</b>						
JT3-2H-4.8x19 E16	19	0 - 4	500		3591911351	4061245026473

## Self-drilling screw JT3-FR-2H-4.8



Cross references	Page
Cordless screwdriver	
ASCM QSW	135
Bit hexalobular TX25	142
FR-tool	143
FR-tool plastic	144

### Application range

- > Side lap stitching of profiled steel and aluminium sheets

### Properties

- > A2 stainless steel with hardened steel drill point
- > Stainless steel sealing washer
- > Pre-assembled sealing washer
- > With free spin zone under screw head for effective side lap stitching
- > With truss head

### Applications

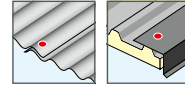

### Technical specifications

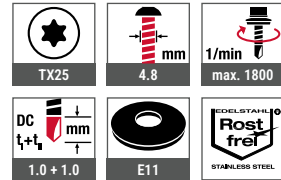

### Certifications



### Assembly instruction



### Product in the online shop



Order description	Length [mm]	Clamping thickness [mm]	PU [pieces]	Price/100 [EUR]	Article number	EAN
<b>Sealing washer E 11, Ø 11 mm</b>						
JT3-FR-2H-4.8x19 E11	19	0 - 4	500		3591968358	4061245047898
JT3-FR-2H-4.8x19 E11 VE100	19	0 - 4	100		6591968358	4061245051888

## Self-drilling screw JT3-2H-Plus-5.5



Cross references	Page
Cordless screwdriver	
ASCM QSW	135
Socket wrench insert SW8	141

### Application range

- > Side lap stitching of profiled steel and aluminium sheets
- > Fastening profiled steel and aluminium sheets to cassette system walls
- > For high-strength steel substructures
- > For fixing profiled steel and aluminium sheet to thin-walled steel and aluminium substructure

### Characteristics

- > A2 stainless steel with hardened drill point
- > Stainless steel sealing washer
- > Pre-assembled sealing washer
- > With free spin zone under screw head for effective side lap stitching

### Applications

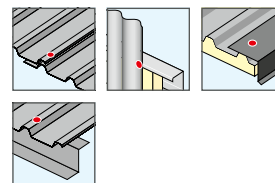

### Technical specifications

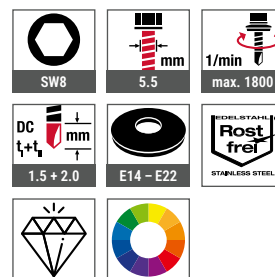

### Assembly instruction



### Product in the online shop



### Certifications

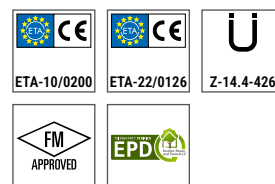

Order description	Length [mm]	Clamping thickness [mm]	PU [pieces]	Price/100 [EUR]	Article number	EAN
<b>Sealing washer E 11, Ø 11 mm</b>						
JT3-2H-Plus-5.5x25 E11 belted	25	0 - 7	560		3380969000	4061245075044
<b>Sealing washer E 14, Ø 14 mm</b>						
JT3-2H-Plus-5.5x25 E14	25	0 - 7	500		3592209391	4061245026442
<b>Sealing washer E 16, Ø 16 mm</b>						
JT3-2H-Plus-5.5x25 E16	25	0 - 7	500		3592211391	4061245015552
JT3-2H-Plus-5.5x25 E16 VE100	25	0 - 7	100		6592211391	4061245014760
JT3-2H-Plus-5.5x25 E16 RAL 7016	25	0 - 7	100		3592211325	4061245034294
JT3-2H-Plus-5.5x25 E16 RAL 9002	25	0 - 7	100		3592211382	4061245034300
JT3-2H-Plus-5.5x25 E16 RAL 9006	25	0 - 7	100		3592211384	4061245034317
JT3-2H-Plus-5.5x25 E16 RAL 9007	25	0 - 7	100		3380911220	4061245044828
JT3-2H-Plus-5.5x30 E16	30	0 - 12	500		3592311391	4061245050126
JT3-2H-Plus-5.5x35 E16	35	0 - 17	500		3592511391	4061245015514
<b>Sealing washer E 19, Ø 19 mm</b>						
JT3-2H-Plus-5.5x25 E19	25	0 - 7	500		3592212391	4061245050218
<b>Sealing washer E 22, Ø 22 mm</b>						
JT3-2H-Plus-5.5x25 E22	25	0 - 7	500		3592213391	4061245026428

Further lengths upon request



Also available in A4 stainless steel



Self-drilling screw  
JT6-2H-plus-5.5  
| Page 78

## Self-drilling screw JT3-FR-2H-Plus-5.5



Cross references	Page
Cordless screwdriver	
ASCM QSW	135
Bit hexalobular TX25	142
FR-tool	143
FR-tool plastic	144

### Application range

- > Side lap stitching of profiled steel and aluminium sheets
- > Fastening profiled steel and aluminium sheets to cassette system walls
- > For high-strength steel substructures

### Properties

- > A2 stainless steel with hardened steel drill point
- > Stainless steel sealing washer
- > Pre-assembled sealing washer
- > With free spin zone under screw head for effective side lap stitching
- > With truss head

### Applications

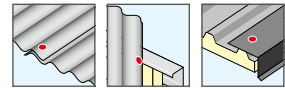

### Technical specifications

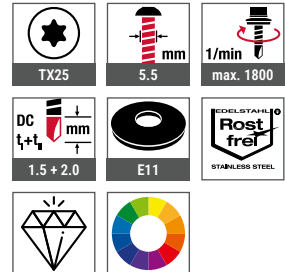

### Certifications

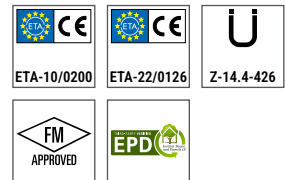

### Assembly instruction



### Product in the online shop



Order description	Length [mm]	Clamping thickness [mm]	PU [pieces]	Price/100 [EUR]	Article number	EAN
<b>Sealing washer E 11, Ø 11 mm</b>						
JT3-FR-2H-Plus-5.5x25 E11	25	0 - 7	500		3592269398	4061245015538
JT3-FR-2H-Plus-5.5x25 E11 VE100	25	0 - 7	100		6592269398	4061245014746
JT3-FR-2H-Plus 5.5x25 E11 RAL 7016	25	0 - 7	100		3390569025	4061245036465
JT3-FR-2H-Plus 5.5x25 E11 RAL 9002	25	0 - 7	100		3390569082	4061245036502
JT3-FR-2H-Plus 5.5x25 E11 RAL 9006	25	0 - 7	100		3390569084	4061245036519
JT3-FR-2H-Plus 5.5x25 E11 RAL 9007	25	0 - 7	100		3390590220	4061245036526
<b>Order information: Further colours upon request</b>						

## Self-drilling screw JT3-2-6.5



### Application range

- > Fastening profiled steel and aluminium sheets, sandwich panels and roofing sheets to timber substructures

### Properties

- > A2 stainless steel with hardened steel drill point
- > Stainless steel sealing washer
- > Pre-assembled sealing washer

### Applications

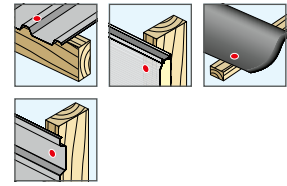

### Technical specifications

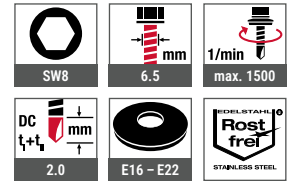

### Certifications



### Cross references

Cross references	Page
ORKAN storm washers	95
Cordless screwdriver	
ASCM QSW	135
Socket wrench insert SW8	141

### Assembly instruction



### Product in the online shop



Order description	Length [mm]	Thread length [mm]	Height component I [mm]	PU [pieces]	Price/100 [EUR]	Article number	EAN
<b>Sealing washer E 16, Ø 16 mm</b>							
JT3-2-6.5x40-E16	40	40	-	250		3594011321	4061245015422
JT3-2-6.5x40 E16 VE100	40	40	-	100		6594011321	4061245014685
JT3-2-6.5x50-E16	50	50	-	250		3598811321	4061245014968
JT3-2-6.5x50 E16 VE100	50	50	-	100		6598811321	4061245014586
JT3-2-6.5x65-E16	65	65	0 - 15	250		3598911321	4061245014951
JT3-2-6.5x65 E16 VE100	65	65	0 - 15	100		6598911321	4061245014579
JT3-2-6.5x80-E16	80	80	0 - 30	250		3598011321	4061245015019
JT3-2-6.5x80 E16 VE100	80	80	0 - 30	100		6598011321	4061245014593
JT3-2-6.5x100-E16	100	80	16 - 50	100		3598111321	4061245014982
JT3-2-6.5x120-E16	120	80	36 - 70	100		3598311321	4061245014975
JT3-2-6.5x140-E16	140	80	56 - 90	100		3598511321	4061245025667
JT3-2-6.5x160-E16	160	80	76 - 110	100		3598711321	4061245025643
JT3-2-6.5x180-E16	180	80	96 - 130	100		3598211321	4061245025698
JT3-2-6.5x200-E16	200	80	116 - 150	100		3599011321	4061245025605
JT3-2-6.5x220-E16	220	80	136 - 170	100		3599111321	4061245116402
JT3-2-6.5x240-E16	240	80	156 - 190	100		3599211321	4061245025568
JT3-2-6.5x260-E16	260	80	176 - 210	100		3599311321	4061245025544
JT3-2-6.5x280-E16	280	80	196 - 230	100		3599511321	4061245025520
JT3-2-6.5x300-E16	300	80	216 - 250	100		3599611321	4061245025506





Order description	Length [mm]	Thread length [mm]	Height component I [mm]	PU [pieces]	Price/100 [EUR]	Article number	EAN
<b>Sealing washer E 19, Ø 19 mm</b>							
JT3-2-6.5x40-E19	40	40	–	250		3594012321	4061245041643
JT3-2-6.5x50-E19	50	50	–	250		3598812321	4061245040707
JT3-2-6.5x65-E19	65	65	0 – 15	250		3598912321	4061245040691
JT3-2-6.5x80-E19	80	80	0 – 30	100		3598012321	4061245040745
JT3-2-6.5x100-E19	100	80	16 – 50	100		3598112321	4061245040721
JT3-2-6.5x120-E19	120	80	36 – 70	100		3598312321	4061245040714
JT3-2-6.5x140-E19	140	80	56 – 90	100		3598512321	4061245049588
JT3-2-6.5x160-E19	160	80	76 – 110	100		3598712321	4061245049571
JT3-2-6.5x180-E19	180	80	96 – 130	100		3598212321	4061245049632
JT3-2-6.5x200-E19	200	80	116 – 150	100		3599012321	4061245049557
JT3-2-6.5x220-E19	220	80	136 – 170	100		3599112321	4061245049540
JT3-2-6.5x240-E19	240	80	156 – 190	50		3599212321	4061245049533
JT3-2-6.5x260-E19	260	80	176 – 210	100		3599312321	4061245049526
JT3-2-6.5x280-E19	280	80	196 – 230	100		3599566321	4061245049496
JT3-2-6.5x300-E19	300	80	216 – 250	100		3599612321	4061245067728
<b>Sealing washer E 22, Ø 22 mm</b>							
JT3-2-6.5x40-E22	40	40	–	250		3594013321	4061245026251
JT3-2-6.5x40 E22 VE100	40	40	–	100		6594013321	4061245025421
JT3-2-6.5x50-E22	50	50	–	250		3598813321	4061245025629
JT3-2-6.5x50 E22 VE100	50	50	–	100		6598813321	4061245025407
JT3-2-6.5x65-E22	65	65	0 – 15	250		3598913321	4061245047232
JT3-2-6.5x65 E22 VE100	65	65	0 – 15	100		6598913321	4061245025391
JT3-2-6.5x80-E22	80	80	0 – 30	100		3598013321	4061245025711
JT3-2-6.5x100-E22	100	80	16 – 50	100		3598113321	4061245025704
JT3-2-6.5x120-E22	120	80	36 – 70	100		3598313321	4061245025674
JT3-2-6.5x140-E22	140	80	56 – 90	100		3598513321	4061245025650
JT3-2-6.5x160-E22	160	80	76 – 110	100		3598713321	4061245025636
JT3-2-6.5x180-E22	180	80	96 – 130	100		3598213321	4061245025681
JT3-2-6.5x200-E22	200	80	116 – 150	100		3599013321	4061245032504
JT3-2-6.5x220-E22	220	80	136 – 170	100		3599113321	4061245025575
JT3-2-6.5x240-E22	240	80	156 – 190	100		3599213321	4061245025551
JT3-2-6.5x260-E22	260	80	176 – 210	100		3599313321	4061245025537
JT3-2-6.5x280-E22	280	80	196 – 230	100		3599513321	4061245025513
JT3-2-6.5x300-E22	300	80	216 – 250	100		3599613321	4061245025490
<b>*Calculated with the setting depth of 50 mm recommended by EJOT. Deviating setting depths possible according to ETA.</b>							

## Self-drilling screw JT3-6-5.5



### Application range

- > Fastening profiled steel and aluminium sheets and sandwich panels to 1.5-4.0 mm steel substructures
- > Fastening profiled aluminium sheets to aluminium substructures 1.5-4.0 mm
- > Fastening profiled aluminium sheets to aluminium substructures (acc. to Z-10.3-701)
- > For high-strength steel substructures

### Properties

- > A2 stainless steel with hardened steel drill point
- > Stainless steel sealing washer
- > Pre-assembled sealing washer

### Notice

\*Z-10.3-701 applies exclusively to the JT3-6-5.5x25 E14

Cross references	Page
ORKAN storm washers	95
Cordless screwdriver	
ASCM QSW	135
Socket wrench insert SW8	141

### Assembly instruction



### Product in the online shop



### Applications

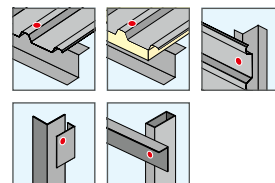

### Technical specifications

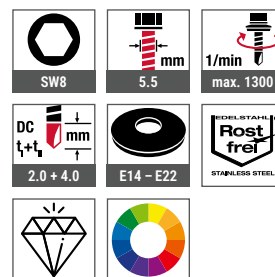

### Certifications

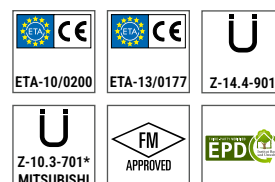

Order description	Length [mm]	Clamping thickness [mm]	PU [pieces]	Price/100 [EUR]	Article number	EAN
<b>Sealing washer E 14, Ø 14 mm</b>						
JT3-6-5.5x25-E14	25	0 - 7	500		3572209361	4061245026664
JT3-6-5.5x30-E14	30	0 - 11	500		3572377361	4061245026589
JT3-6-5.5x35-E14	35	0 - 16	500		3572577361	4061245026541
<b>Sealing washer E 16, Ø 16 mm</b>						
JT3-6-5.5x25-E16	25	0 - 7	500		3572211361	4061245015699
JT3-6-5.5x25 E16 VE100	25	0 - 7	100		6572211361	4061245014852
JT3-6-5.5x25 E16 RAL 7016	25	0 - 7	100		3532211625	4061245034447
JT3-6-5.5x25 E16 RAL 9002	25	0 - 7	100		3532211682	4061245034539
JT3-6-5.5x25 E16 RAL 9006	25	0 - 7	100		3532211684	4061245034546
JT3-6-5.5x25 E16 RAL 9007	25	0 - 7	100		3381011220	4061245034553
JT3-6-5.5x30-E16	30	0 - 11	500		3572311361	4061245015675
JT3-6-5.5x30 E16 VE100	30	0 - 11	100		6572311361	4061245014845
JT3-6-5.5x35-E16	35	0 - 16	500		3572511361	4061245015668
JT3-6-5.5x35 E16 VE100	35	0 - 16	100		6572511361	4061245014838
JT3-6-5.5x50-E16	50	0 - 31	250		3592811361	4061245015484
JT3-6-5.5x50 E16 VE100	50	0 - 31	100		6592811361	4061245014722
JT3-6-5.5x70-E16	70	22 - 51	250		3593911361	4061245015439
JT3-6-5.5x70 E16 VE100	70	22 - 51	100		6593911361	4061245014692





Order description	Length [mm]	Clamping thickness [mm]	PU [pieces]	Price/100 [EUR]	Article number	EAN
JT3-6-5.5x90-E16	90	42 – 71	250		3596111361	4061245015118
JT3-6-5.5x90 E16 VE100	90	42 – 71	100		6596111361	4061245014616
JT3-6-5.5x110-E16	110	62 – 91	100		3596211361	4061245015101
JT3-6-5.5x130-E16	130	82 – 111	100		3596311361	4061245015095
JT3-6-5.5x150-E16	150	102 – 131	100		3596411361	4061245015088
JT3-6-5.5x170-E16	170	122 – 151	100		3596511361	4061245015071
JT3-6-5.5x190-E16	190	142 – 171	100		3596611361	4061245015064
<b>Sealing washer E 19, Ø 19 mm</b>						
JT3-6-5.5x25-E19	25	0 – 7	500		3572212361	4061245026657
JT3-6-5.5x30-E19	30	0 – 11	500		3572312361	4061245026602
JT3-6-5.5x35-E19	35	0 – 16	500		3572512361	4061245026572
JT3-6-5.5x50-E19	50	0 – 31	250		3592812361	4061245032306
JT3-6-5.5x70-E19	70	22 – 51	250		3593912361	4061245026299
JT3-6-5.5x90-E19	90	42 – 71	100		3596112361	4061245025872
JT3-6-5.5x110-E19	110	62 – 91	100		3596212361	4061245025841
JT3-6-5.5x130-E19	130	82 – 111	100		3596312361	4061245032436
JT3-6-5.5x150-E19	150	102 – 131	100		3596412361	4061245025780
JT3-6-5.5x170-E19	170	122 – 151	100		3596512361	4061245025766
JT3-6-5.5x190-E19	190	142 – 171	100		3596666361	4061245025735
<b>Sealing washer E 22, Ø 22 mm</b>						
JT3-6-5.5x25-E22	25	0 – 7	500		3572213361	4061245026640
JT3-6-5.5x25 E22 VE100	25	0 – 7	100		6572213361	4061245051963
JT3-6-5.5x30-E22	30	0 – 11	500		3572313361	4061245026596
JT3-6-5.5x35-E22	35	0 – 16	500		3572513361	4061245026565
JT3-6-5.5x50-E22	50	0 – 31	250		3592813361	4061245026367
JT3-6-5.5x70-E22	70	22 – 51	250		3593913361	4061245026282
JT3-6-5.5x90-E22	90	42 – 71	100		3596113361	4061245025865
JT3-6-5.5x110-E22	110	62 – 91	100		3596213361	4061245025834
JT3-6-5.5x130-E22	130	82 – 111	100		3596313361	4061245025797
JT3-6-5.5x150-E22	150	102 – 131	100		3596413361	4061245025773
JT3-6-5.5x170-E22	170	122 – 151	100		3596513361	4061245025759
JT3-6-5.5x190-E22	190	142 – 171	100		3596613361	4061245025742
<b>Order information: Further RAL colours upon request</b>						

Further lengths upon request



Also available in A4 stainless steel



Self-drilling screw  
JT6-6-5.5  
| Page 79

## Self-drilling screw JT3-FR-6-5.5



**Cross references** **Page**

Cordless screwdriver	
ASCM QSW	135
Bit hexalobular TX25	142
FR-tool	143
FR-tool plastic	144

**Assembly instruction**



**Product in the online shop**



**Application range**

- > Fastening corrugated profile steel sheets to 1.5–4 mm steel substructure
- > Fastening profiled aluminium sheets to 1.5-4 mm steel or 2-5 mm aluminium substructures

**Properties**

- > A2 stainless steel with hardened steel drill point
- > Stainless steel sealing washer
- > Pre-assembled sealing washer
- > With truss head

**Applications**

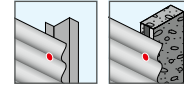

**Technical specifications**

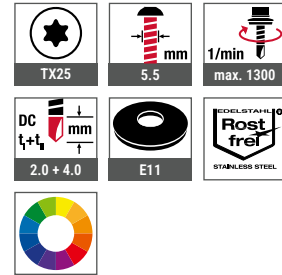

**Certifications**



Order description	Length [mm]	Clamping thickness [mm]	PU [pieces]	Price/100 [EUR]	Article number	EAN
<b>Sealing washer E 11, Ø 11 mm</b>						
JT3-FR-6-5.5x25 E11	25	0 – 7	500		3592269368	4061245015545
JT3-FR-6-5.5x25 E11 VE100	25	0 – 7	100		6592269368	4061245014753
JT3-FR-6-5.5x25 E11 RAL 7016	25	0 – 7	100		3390469025	4061245034966
JT3-FR-6-5.5x25 E11 RAL 9002	25	0 – 7	100		3390469082	4061245034980
JT3-FR-6-5.5x25 E11 RAL 9006	25	0 – 7	100		3390469084	4061245035000
JT3-FR-6-5.5x25 E11 RAL 9007	25	0 – 7	100		3390469220	4061245035017
JT3-FR-6-5.5x35 E11	35	0 – 17	500		3592569368	4061245015491
JT3-FR-6-5.5x35 E11 VE100	35	0 – 17	100		6592569368	4061245014739
Order information: Further RAL colours upon request						

## Self-drilling screw JT3-6-6.3

**Application range**

- > Fastening profiled steel sheets to 2–5 mm steel substructure

**Properties**

- > A2 stainless steel with hardened steel drill point
- > Stainless steel sealing washer
- > Pre-assembled sealing washer

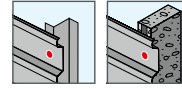
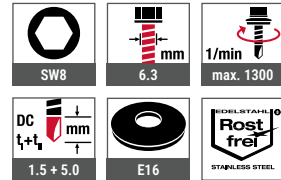
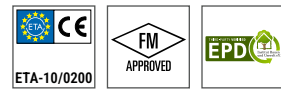
**Applications****Technical specifications****Certifications****Assembly instruction****Product in the online shop****Cross references**

	Page
Cordless screwdriver	
ASCM QSW	135
Socket wrench insert SW8	141

**Order description****Sealing washer E 16, Ø 16 mm**

	Length [mm]	Clamping thickness [mm]	PU [pieces]	Price/100 [EUR]	Article number	EAN
JT3-6-6.3x25-E16	25	0 – 7	500		3599411361	4061245036847

## Self-drilling screw JT3-12-5.5

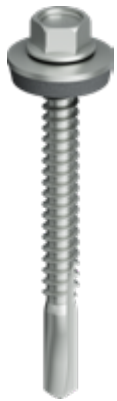

### Application range

- > Fastening profiled steel and aluminium sheets and sandwich panels to 4-10 mm steel substructures
- > Fastening aluminium profiled sheets to 4-12 mm aluminium substructures

### Properties

- > A2 stainless steel with hardened steel drill point
- > Stainless steel sealing washer
- > Pre-assembled sealing washer

### Applications

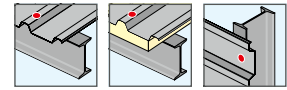

### Technical specifications

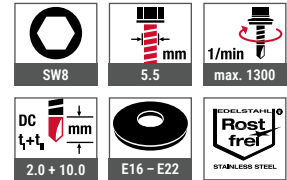

### Certifications

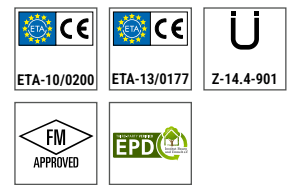

Cross references	Page
ORKAN storm washers	95
Cordless screwdriver	
ASCM QSW	135
Socket wrench insert SW8	141

### Assembly instruction



### Product in the online shop



Order description	Length [mm]	Clamping thickness [mm]	PU [pieces]	Price/100 [EUR]	Article number	EAN
<b>Sealing washer E 16, Ø 16 mm</b>						
JT3-12-5.5x40-E16	40	0 - 11	500		3595611311	4061245015187
JT3-12-5.5x40 E16 VE100	40	0 - 11	100		6595611311	4061245014630
JT3-12-5.5x58 E16	58	0 - 31	250		3595811311	4061245015132
JT3-12-5.5x58 E16 VE100	58	0 - 31	100		6595811311	4061245014623
JT3-12-5.5x78-E16	78	25 - 51	250		3595011311	4061245015316
JT3-12-5.5x78 E16 VE100	78	25 - 51	100		6595011311	4061245014647
JT3-12-5.5x98-E16	98	45 - 71	100		3595111311	4061245015286
JT3-12-5.5x118-E16	118	65 - 91	100		3595211311	4061245015262
JT3-12-5.5x138-E16	138	85 - 111	100		3595311311	4061245015248
JT3-12-5.5x158-E16	158	105 - 131	100		3595411311	4061245015224
JT3-12-5.5x178-E16	178	125 - 151	100		3595511311	4061245015217
JT3-12-5.5x198-E16	198	145 - 171	100		3595711311	4061245015156
<b>Sealing washer E 19, Ø 19 mm</b>						
JT3-12-5.5x40-E19	40	0 - 11	500		3595612311	4061245040837
JT3-12-5.5x58-E19	58	0 - 31	250		3595812311	4061245025896
JT3-12-5.5x78-E19	78	25 - 51	250		3595012311	4061245026145
JT3-12-5.5x98-E19	98	45 - 71	100		3595112311	4061245116600





Order description	Length [mm]	Clamping thickness [mm]	PU [pieces]	Price/100 [EUR]	Article number	EAN
JT3-12-5.5x118-E19	118	65 – 91	100		3595212311	4061245026053
JT3-12-5.5x138-E19	138	85 – 111	100		3595312311	4061245026022
JT3-12-5.5x158-E19	158	105 – 131	100		3595412311	4061245025995
JT3-12-5.5x178-E19	178	125 – 151	100		3595512311	4061245025971
JT3-12-5.5x198-E19	198	145 – 171	100		3595712311	4061245025919
<b>Sealing washer E 22, Ø 22 mm</b>						
JT3-12-5.5x40-E22	40	0 – 11	250		3595613311	4061245025926
JT3-12-5.5x40 E22 VE100	40	0 – 11	100		6595613311	4061245025414
JT3-12-5.5x58 E22	58	0 – 31	250		3595813311	4061245025889
JT3-12-5.5x78-E22	78	25 – 51	250		3595013311	4061245026138
JT3-12-5.5x98-E22	98	45 – 71	100		3595113311	4061245026091
JT3-12-5.5x118-E22	118	65 – 91	100		3595213311	4061245026046
JT3-12-5.5x138-E22	138	85 – 111	100		3595313311	4061245026015
JT3-12-5.5x158-E22	158	105 – 131	100		3595413311	4061245025988
JT3-12-5.5x178-E22	178	125 – 151	100		3595513311	4061245025964
JT3-12-5.5x198-E22	198	145 – 171	100		3595713311	4061245025902

Further lengths upon request



Also available in A4 stainless steel



Self-drilling screw  
JT6-12-5.5  
| Page 80

## Self-drilling screw JT3-FR-12-5.5



### Application range

- > Fastening profiled steel and aluminium sheets to 4-10 mm steel substructures
- > Fastening profiled aluminium sheets to 4-12 mm aluminium substructures

### Properties

- > A2 stainless steel with hardened steel drill point
- > Stainless steel sealing washer
- > Pre-assembled sealing washer
- > With truss head

### Applications



### Technical specifications

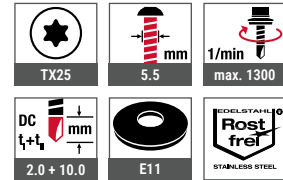

### Certifications



Cross references	Page
Cordless screwdriver	
ASCM QSW	135
Bit hexalobular TX25	142
FR-tool	143
FR-tool plastic	144

### Assembly instruction



### Product in the online shop



Order description	Length [mm]	Clamping thickness [mm]	PU [pieces]	Price/100 [EUR]	Article number	EAN
<b>Sealing washer E 11, Ø 11 mm</b>						
JT3-FR-12-5.5x40 E11	40	0 - 11	500		3595669318	4061245015170
Order information: RAL colours upon request						

## Self-drilling screw JT3-18-5.5

**Application range**

- > Fastening profiled steel and aluminium sheets and sandwich panels to 4-16 mm steel substructures

**Properties**

- > A2 stainless steel with hardened steel drill point
- > Stainless steel sealing washer
- > Pre-assembled sealing washer

Cross references	Page
ORKAN storm washers	95
Cordless screwdriver	
ASCM QSW	135
Socket wrench insert SW8	144

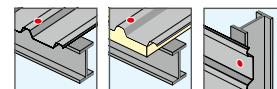
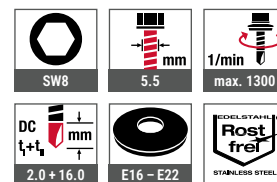
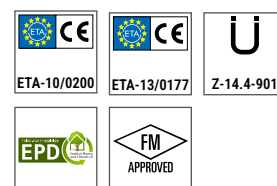
**Applications****Technical specifications****Certifications****Assembly instruction****Product in the online shop**

Order description	Length [mm]	Clamping thickness [mm]	PU [pieces]	Price/100 [EUR]	Article number	EAN
<b>Sealing washer E 16, Ø 16 mm</b>						
JT3-18-5.5x55-E16	55	0 - 18	500		3593011381	4061245015477
JT3-18-5.5x115-E16	115	40 - 78	100		3595011381	4061245015309
JT3-18-5.5x155-E16	155	80 - 118	100		3595511381	4061245015194
JT3-18-5.5x195-E16	195	120 - 158	100		3596011381	4061245015125
JT3-18-5.5x235-E16	235	160 - 198	100		3597511381	4061245015033
JT3-18-5.5x275-E16	275	200 - 238	100		3598011381	4061245015002
<b>Sealing washer E 19, Ø 19 mm</b>						
JT3-18-5.5x55-E19	55	0 - 18	250		3593012381	4061245041018
JT3-18-5.5x115-E19	115	40 - 78	100		3595012381	4061245040929
JT3-18-5.5x155-E19	155	80 - 118	100		3595512381	4061245040851
JT3-18-5.5x195-E19	195	120 - 158	100		3596012381	4061245040783
JT3-18-5.5x235-E19	235	160 - 198	100		3597512381	4061245040752
JT3-18-5.5x275-E19	275	200 - 238	100		3598012381	4061245044453
<b>Sealing washer E 22, Ø 22 mm</b>						
JT3-18-5.5x55-E22	55	0 - 18	250		3593013381	4061245026336
JT3-18-5.5x115-E22	115	40 - 78	100		3595013381	4061245040912
JT3-18-5.5x155-E22	155	80 - 118	100		3595513381	4061245040844
JT3-18-5.5x195-E22	195	120 - 158	100		3596013381	4061245040776
JT3-18-5.5x235-E22	235	160 - 198	100		3597513381	4061245044446
JT3-18-5.5x275-E22	275	200 - 238	100		3598013381	4061245040738

## Self-drilling screw JT3-D-6H-5.5/6.3



### Application range

- > For fixing sandwich panels to 1.5–4 mm steel substructures
- > For high-strength steel substructures

### Properties

- > A2 stainless steel with hardened steel drill point
- > Stainless steel sealing washer
- > Pre-assembled sealing washer
- > With free spin zone under the screw head
- > High thread

### Applications



### Technical specifications

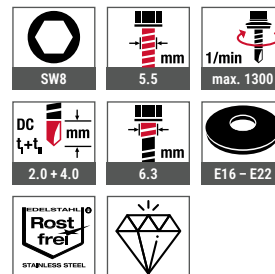

### Certifications



### Cross references

	Page
Cordless screwdriver	
ASCM QSW	135
Socket wrench insert SW8	141

### Assembly instruction



### Product in the online shop



Order description	Length [mm]	Clamping thickness [mm]	PU [pieces]	Price/100 [EUR]	Article number	EAN
<b>Sealing washer E 16, Ø 16 mm</b>						
JT3-D-6H-5.5/6.3x67 E16	67	30 – 48	250		3554511372	4061245027241
JT3-D-6H-5.5/6.3x87 E16	87	41 – 68	250		3556011371	4061245027142
JT3-D-6H-5.5/6.3x107 E16	107	51 – 88	100		3556111371	4061245027128
JT3-D-6H-5.5/6.3x127 E16	127	71 – 108	100		3556211371	4061245027104
JT3-D-6H-5.5/6.3x147 E16	147	91 – 128	100		3556311371	4061245027081
JT3-D-6H-5.5/6.3x167 E16	167	111 – 148	100		3556711371	4061245027043
JT3-D-6H-5.5/6.3x197 E16	197	141 – 178	100		3559711372	4061245026725
JT3-D-6H-5.5/6.3x237 E16	237	171 – 218	100		3559611372	4061245026749
JT3-D-6H-5.5/6.3x267 E16	267	201 – 248	100		3559911372	4061245026688
<b>Sealing washer E 19, Ø 19 mm</b>						
JT3-D-6H-5.5/6.3x67 E19	67	30 – 48	100		3554566372	4061245016047
JT3-D-6H-5.5/6.3x87 E19	87	41 – 68	100		3556066371	4061245015989
JT3-D-6H-5.5/6.3x107 E19	107	51 – 88	100		3556166371	4061245015972
JT3-D-6H-5.5/6.3x127 E19	127	71 – 108	100		3556266371	4061245015965
JT3-D-6H-5.5/6.3x147 E19	147	91 – 128	100		3556366371	4061245015941
JT3-D-6H-5.5/6.3x167 E19	167	111 – 148	100		3556766371	4061245015910





Order description	Length [mm]	Clamping thickness [mm]	PU [pieces]	Price/100 [EUR]	Article number	EAN
JT3-D-6H-5.5/6.3x197 E19	197	141 – 178	100		3559766372	4061245015743
JT3-D-6H-5.5/6.3x237 E19	237	171 – 218	100		3559666372	4061245015767
JT3-D-6H-5.5/6.3x267 E19	267	201 – 248	100		3559966372	4061245015705
<b>Sealing washer E 22, Ø 22 mm</b>						
JT3-D-6H-5.5/6.3x67 E22	67	30 – 48	100		3554513372	4061245027234
JT3-D-6H-5.5/6.3x87 E22	87	41 – 68	100		3556013371	4061245027135
JT3-D-6H-5.5/6.3x107 E22	107	51 – 88	100		3556113371	4061245027111
JT3-D-6H-5.5/6.3x127 E22	127	71 – 108	100		3556213371	4061245027098
JT3-D-6H-5.5/6.3x147 E22	147	91 – 128	100		3556313371	4061245027074
JT3-D-6H-5.5/6.3x167 E22	167	111 – 148	100		3556713371	4061245027036
JT3-D-6H-5.5/6.3x197 E22	197	141 – 178	100		3559713372	4061245032610
JT3-D-6H-5.5/6.3x237 E22	237	171 – 218	100		3559613372	4061245026732
JT3-D-6H-5.5/6.3x267 E22	267	201 – 248	100		3559913372	4061245026671

Other variants available upon request



A4 stainless steel available upon request



Self-drilling screw  
JT6-D-6H-5.5/6.3

## Self-drilling screw JT3-D-12H-5.5/6.3



### Application range

- > For fixing sandwich elements to 3–12 mm steel substructures

### Properties

- > A2 stainless steel with hardened steel drill point
- > Stainless steel sealing washer
- > Pre-assembled sealing washer
- > With free spin zone under the screw head
- > High thread

### Applications



### Technical specifications

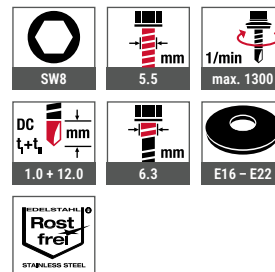

### Certifications

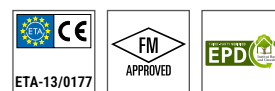

### Cross references

Cross references	Page
Cordless screwdriver	
ASCM QSW	135
Socket wrench insert SW8	141

### Assembly instruction



### Product in the online shop



Order description	Length [mm]	Clamping thickness [mm]	PU [pieces]	Price/100 [EUR]	Article number	EAN
<b>Sealing washer E 16, Ø 16 mm</b>						
JT3-D-12H-5.5/6.3x75 E16	75	41 – 48	250		3557511312	4061245026985
JT3-D-12H-5.5/6.3x95 E16	95	51 – 68	100		3554911311	4061245027227
JT3-D-12H-5.5/6.3x115 E16	115	61 – 88	100		3555211311	4061245027203
JT3-D-12H-5.5/6.3x135 E16	135	73 – 108	100		3555411311	4061245027180
JT3-D-12H-5.5/6.3x155 E16	155	93 – 128	100		3555711311	4061245027166
JT3-D-12H-5.5/6.3x175 E16	175	113 – 148	100		3556511312	4061245027067
JT3-D-12H-5.5/6.3x195 E16	195	133 – 168	100		3559511312	4061245026763
JT3-D-12H-5.5/6.3x215 E16	215	153 – 188	100		3559611312	4061245041025
JT3-D-12H-5.5/6.3x245 E16	245	183 – 218	100		3559811312	4061245026701
JT3-D-12H-5.5/6.3x275 E16	275	213 – 248	100		3557311312	4061245027029
JT3-D-12H-5.5/6.3x300 E16	300	243 – 278	100		3557411312	4061245027005
<b>Sealing washer E 19, Ø 19 mm</b>						
JT3-D-12H-5.5/6.3x75 E19	75	41 – 48	100		3557566312	4061245015873
JT3-D-12H-5.5/6.3x95 E19	95	51 – 68	100		3554966311	4061245016030
JT3-D-12H-5.5/6.3x115 E19	115	61 – 88	100		3555266311	4061245016023
JT3-D-12H-5.5/6.3x135 E19	135	73 – 108	100		3555466311	4061245016016





Order description	Length [mm]	Clamping thickness [mm]	PU [pieces]	Price/100 [EUR]	Article number	EAN
JT3-D-12H-5.5/6.3x155 E19	155	93 – 128	100		3555766311	4061245009155
JT3-D-12H-5.5/6.3x175 E19	175	113 – 148	100		3556566312	4061245009162
JT3-D-12H-5.5/6.3x195 E19	195	133 – 168	100		3559566312	4061245009179
JT3-D-12H-5.5/6.3x215 E19	215	153 – 188	100		3559666312	4061245015774
JT3-D-12H-5.5/6.3x245 E19	245	183 – 218	100		3559866312	4061245015729
JT3-D-12H-5.5/6.3x275 E19	275	213 – 248	100		3557366312	4061245015897
JT3-D-12H-5.5/6.3x300 E19	300	243 – 278	100		3557466312	4061245015880
<b>Sealing washer E 22, Ø 22 mm</b>						
JT3-D-12H-5.5/6.3x75 E22	75	41 – 48	100		3557513312	4061245026978
JT3-D-12H-5.5/6.3x95 E22	95	51 – 68	100		3554913311	4061245027210
JT3-D-12H-5.5/6.3x115 E22	115	61 – 88	100		3555213311	4061245027197
JT3-D-12H-5.5/6.3x135 E22	135	73 – 108	100		3555413311	4061245027173
JT3-D-12H-5.5/6.3x155 E22	155	93 – 128	100		3555713311	4061245027159
JT3-D-12H-5.5/6.3x175 E22	175	113 – 148	100		3556513312	4061245027050
JT3-D-12H-5.5/6.3x195 E22	195	133 – 168	100		3559513312	4061245026756
JT3-D-12H-5.5/6.3x215 E22	215	153 – 188	100		3559613312	4061245044484
JT3-D-12H-5.5/6.3x245 E22	245	183 – 218	100		3559813312	4061245026695
JT3-D-12H-5.5/6.3x275 E22	275	213 – 248	100		3557313312	4061245027012
JT3-D-12H-5.5/6.3x300 E22	300	243 – 278	100		3557413312	4061245026992

Further lengths upon request



A4 stainless steel available upon request



Self-drilling screw  
JT6-D-12H-5.5/6.3

# Concrete screw JC6-D-7.5

Sandwich fasteners with new high thread geometry for direct fastening of sandwich panels to concrete substructures

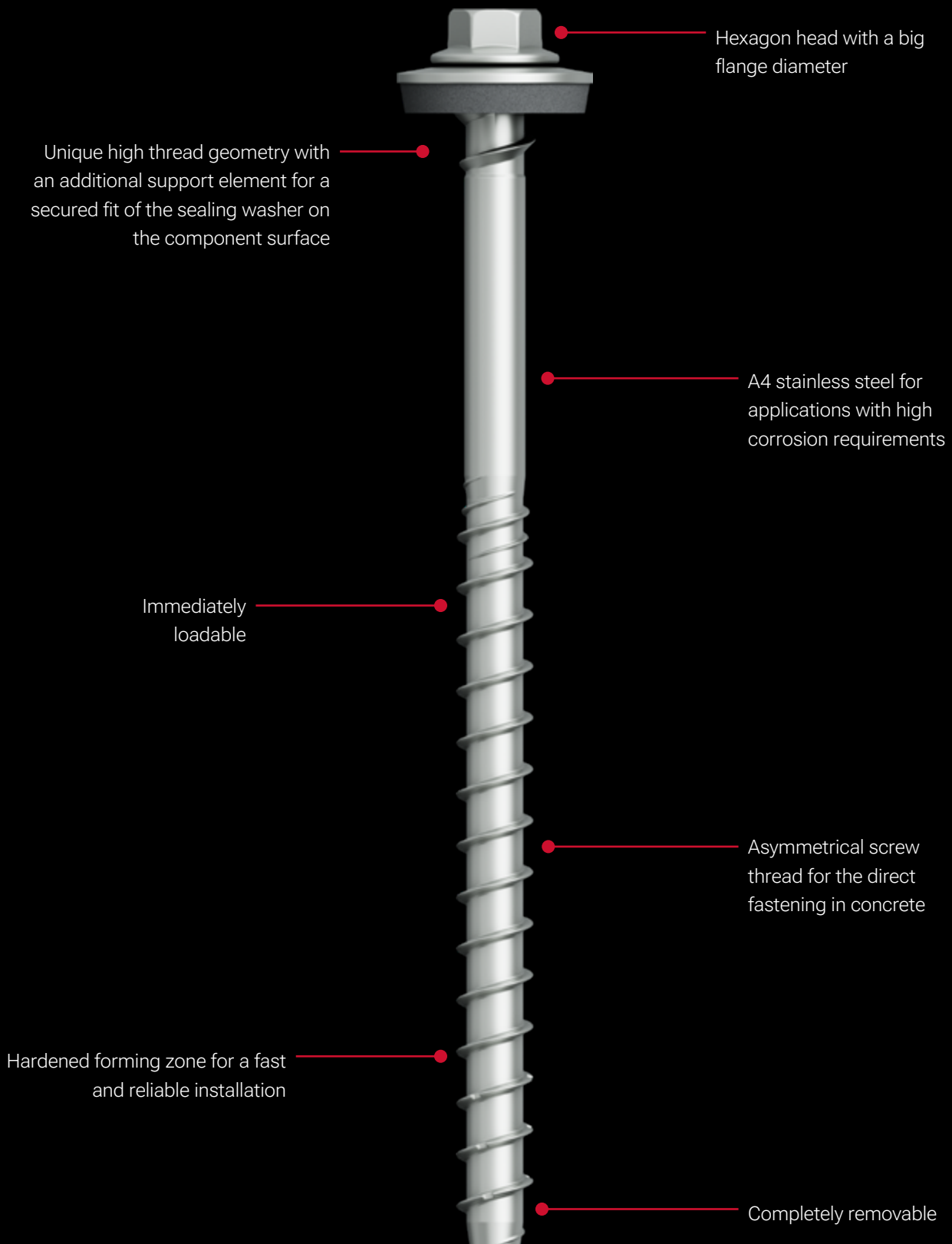

## Concrete screw JC6-D-7.5

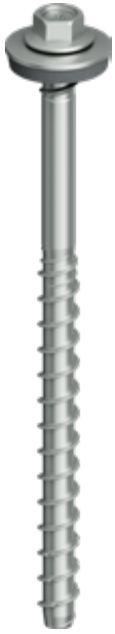
**Application range**

- > Direct fastening of sandwich panels to concrete substructures

**Properties**

- > A4 stainless steel with hardened forming zone
- > Stainless steel sealing washer
- > Pre-assembled sealing washer
- > Unique high thread geometry

**Advantages**

- > Immediately loadable
- > Completely removable
- > No insertion rail necessary

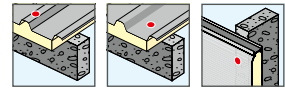
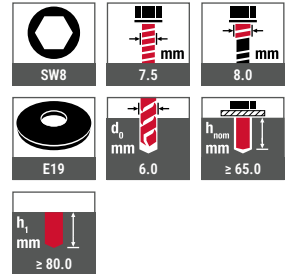
**Applications****Technical specifications****Certifications**

ETA-21/1107

**Base materials****Suitable for**

- > Cracked concrete
- > Non-cracked concrete

**Assembly instruction****Product in the online shop****Cross references**

Cross references	Page
ORKAN storm washers	95
Cordless impact screwdrivers	136
Cordless hammer drill ABH	137
Precision drill bit HSS	139
Hammer drill SDS plus®	140
Socket wrench insert SW8 1/2"	141

Order description	L [mm]	Height component l [mm]	PU [pieces]	Price/100 [EUR]	Article number	EAN
<b>Sealing washer E 19, Ø 19 mm</b>						
JC6-D-7.5x115 E19	115	37 – 47	100		3551082991	4061245123431
JC6-D-7.5x135 E19	135	57 – 67	100		3551182991	4061245123448
JC6-D-7.5x155 E19	155	77 – 87	50		3551282991	4061245117614
JC6-D-7.5x175 E19	175	97 – 107	50		3551382991	4061245117621
JC6-D-7.5x195 E19	195	117 – 127	50		3551482991	4061245117638
JC6-D-7.5x215 E19	215	137 – 147	50		3551582991	4061245117539
JC6-D-7.5x235 E19	235	157 – 167	50		3551682991	4061245117546
JC6-D-7.5x255 E19	255	177 – 187	50		3551782991	4061245117553
JC6-D-7.5x275 E19	275	197 – 207	50		3551882991	4061245117577
JC6-D-7.5x295 E19	295	217 – 227	50		3551982991	4061245117584

## Self-drilling screw JT3-ST-2-6.0



### Application range

- > Fastening rail systems with intermediate insulation to thin-walled steel, aluminium or timber substructure
- > Fastening timber components to thin-walled steel or aluminium substructure
- > To fix roofing membranes and insulating material to substructures made of sheet steel  $\geq 0.70$  in mm  $\leq 1.5$  mm, timber or wood-based material in combination with EJOT stress plates

### Properties

- > A2 stainless steel with hardened steel drill point
- > With countersunk head

### Applications

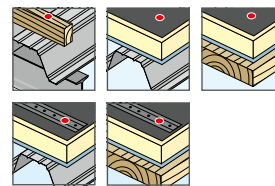

### Technical specifications

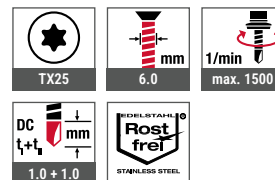

### Certifications

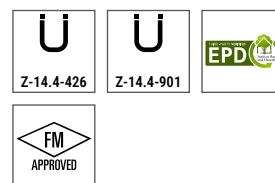

Cross references	Page
Cordless screwdriver	
ASCM QSW	135
Bit hexalobular TX25	142
Bit holder	143

### Assembly instruction



### Product in the online shop



Order description	Length [mm]	Thread length [mm]	Clamping thickness [mm]	PU [pieces]	Price/100 [EUR]	Article number	EAN
JT3-ST-2-6.0x35	35	35	0 – 20	500		7382160301	4061245014104
JT3-ST-2-6.0x60	60	45	15 – 45	250		7382125301	4061245014111
JT3-ST-2-6.0x80	80	65	15 – 65	250		7382107301	4061245014128
JT3-ST-2-6.0x100	100	65	35 – 85	250		7382101301	4061245014180
JT3-ST-2-6.0x120	120	65	55 – 105	250		7382102301	4061245014173
JT3-ST-2-6.0x140	140	65	75 – 125	250		7382103301	4061245014166
JT3-ST-2-6.0x160	160	65	95 – 145	100		7382104301	4061245014159
JT3-ST-2-6.0x180	180	65	115 – 165	100		7382105301	4061245014142
JT3-ST-2-6.0x200	200	65	135 – 185	100		7382106301	4061245014135

Further lengths upon request



## Self-drilling screw JT3-X-2-6.0



Cross references	Page
Cordless screwdriver	
ASCM QSW	135
Socket wrench insert SW8	141

### Application range

- > Fixing standing seam systems (clips) to 0.55–1.5 mm steel substructure
- > Fixing standing seam systems on milled system rails ≤ 1.5 mm
- > Fixing standing seam systems (clips) to 0.8–1.5 mm aluminium substructure or timber substructure

### Properties

- > A2 stainless steel with hardened steel drill point
- > Under-head serrations to increase the installation reliability
- > Special thread for thin-walled components
- > High stripping torque
- > Installation without special tools

### Applications

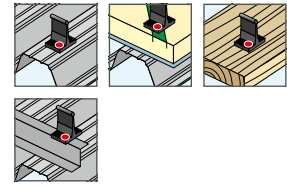

### Technical specifications

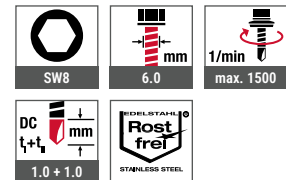

### Certifications

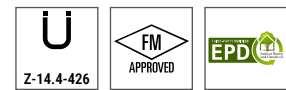

### Assembly instruction



### Product in the online shop



Order description	Length [mm]	Clamping thickness [mm]	PU [pieces]	Price/100 [EUR]	Article number	EAN
JT3-X-2-6.0x25	25	0 – 10	500		7380539301	4061245014296
JT3-X-2-6.0x36	36	0 – 20	500		7380516301	4061245014319
JT3-X-2-6.0x46	46	0 – 30	500		7380517301	4061245014302

## Self-drilling screw JT3-WD-6-5.5



### Application range

- > Special screw for fastening wood to steel substructures

### Properties

- > A2 stainless steel with hardened steel drill point
- > With full thread
- > The wings widen the drill hole in the wood component to be fastened in order to prevent forced feed. They break off as soon as they touch the steel substructure. This prevents the wood to be fastened from being pushed away from the substructure.

### Notice

To ensure shearing of the wings, the material thickness of the steel substructure must be at least 2.0 mm

### Applications



### Technical specifications

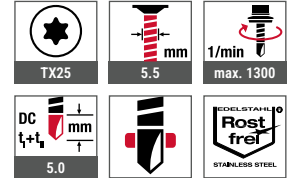

### Certifications



### Cross references

Cross references	Page
Cordless screwdriver	
ASCM QSW	135
Bit hexalobular TX25	142
Bit holder	143



### Assembly instruction



### Product in the online shop



Order description	Length [mm]	Clamping thickness [mm]	PU [pieces]	Price/100 [EUR]	Article number	EAN
JT3-WD-6-5.5x45-R	45	0 – 26	500		7382195301	4061245014081
JT3-WD-6-5.5x65-R	65	0 – 46	500		7382194301	4061245014098

## Self-drilling screw JT3-2H-(40/80)-6.0/6.0



### Application range

- > Spacer bolt for fastening profiled steel and aluminium sheets to cassette bars with insulation
- > Fastening lesenes to insulated cassette bars
- > Also suitable for fastening shear-deformable wall claddings
- > For 40 and 80 mm insulations

### Properties

- > A2 stainless steel with hardened steel drill point
- > Stainless steel sealing washer
- > Pre-assembled sealing washer
- > Special thread geometry allows a removal of the screw
- > No pre-drilling of the outer leaf required



### Application example

Fastening of profiled ceiling elements and lesenes to insulated cassette wall systems.

Cross references	Page
Cordless screwdriver	
ASCM QSW	135
Socket wrench insert SW8	141

### Applications



### Technical specifications

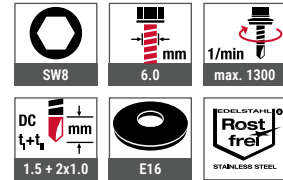

### Certifications

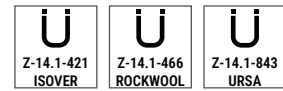

### Product video



### Assembly instruction



### Product in the online shop



Order description	Length [mm]	For insulation [mm]	PU [pieces]	Price/100 [EUR]	Article number	EAN
<b>Sealing washer E 16, Ø 16 mm</b>						
JT3-2H-40-6.0/6.0x64 E16	64	40	100		3594011351	4061245041001
JT3-2H-80-6.0/6.0x104 E16	104	80	100		3594211351	4061245040998

## Self-drilling screw JT4-4-4.8



### Application range

- > Fastening aluminium profiles to aluminium substructures ≤ 3 mm

### Characteristics

- > A2 stainless steel

### Applications



### Technical specifications

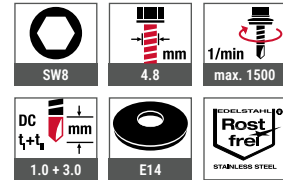

### Certifications



Cross references	Page
Cordless screwdriver	
ASCM QSW	135
Socket wrench insert SW8	141

### Assembly instruction



### Product in the online shop



Order description	Length [mm]	Clamping thickness [mm]	PU [pieces]	Price/100 [EUR]	Article number	EAN
JT4-4-4.8x19	19	0 - 9	1000		7380387300	4061245014357
JT4-4-4.8x19 VE100	19	0 - 9	100		6380387300	4061245014883
<b>Sealing washer E 14, Ø 14 mm</b>						
JT4-4-4.8x19-E14	19	0 - 6	500		3501909440	4061245027302

## Self-drilling screw JT4-6-5.5

**Application range**

- > Fastening aluminium profiles to aluminium substructures  
≤ 4 mm

**Properties**

- > A2 stainless steel

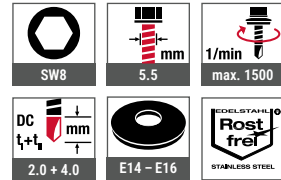
**Applications****Technical specifications****Certifications****Assembly instruction****Product in the online shop**

Cross references	Page
Cordless screwdriver	
ASCM QSW	135
Socket wrench insert SW8	141

Order description	Length [mm]	Clamping thickness [mm]	PU [pieces]	Price/100 [EUR]	Article number	EAN
JT4-6-5.5x22	22	0 - 10	500		7380508301	4061245014340
JT4-6-5.5x22 VE100	22	0 - 10	100		6380508301	4061245025452
JT4-6-5.5x30	30	0 - 18	500		7380509301	4061245014326
<b>Sealing washer E 14, Ø 14 mm</b>						
JT4-6-5.5x22-E14	22	0 - 7	500		3502109460	4061245027272
JT4-6-5.5x30-E14	30	0 - 15	500		3502309461	4061245027258
<b>Sealing washer E 16, Ø 16 mm</b>						
JT4-6-5.5x22-E16	22	0 - 7	500		3502111460	4061245027265
JT4-6-5.5x30-E16	30	0 - 15	500		3502311461	4061245050720

## Self-drilling screw JT4-FR-2-4.9



### Application range

- > Fastening corrugated profile aluminium sheets to timber substructure
- > Fastening of sandwich panels to timber substructure

### Properties

- > A2 stainless steel
- > Stainless steel sealing washer
- > Pre-assembled sealing washer
- > Thread according to DIN 7998
- > With truss head

### Applications



### Technical specifications

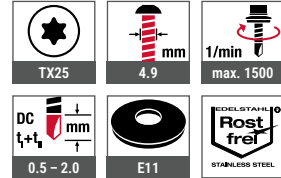

### Certifications



Cross references	Page
Cordless screwdriver	
ASCM QSW	135
Bit hexalobular TX25	142
FR-tool	143
FR-tool plastic	144

### Assembly instruction



### Product in the online shop



Order description	Length [mm]	Thickness component I [mm]	PU [pieces]	Price/100 [EUR]	Article number	EAN
<b>Sealing washer E 11, Ø 11 mm</b>						
JT4-FR-2-4.9x35 E11	35	0 - 7	500		3503568420	4061245016108

## Self-drilling screw JT4-FR-4-4.8



Cross references	Page
Sealing washers	126
Cordless screwdriver	
ASCM QSW	135
Bit hexalobular TX25	142
FR-tool	143
FR-tool plastic	144

**Application range**

- > Fastening aluminium corrugated profile sheet to aluminium substructure  $\leq 3$  mm
- > Fastening facade cladding to aluminium substructure

**Properties**

- > A2 stainless steel
- > With truss head

**Notice**

Please note the respective approval of the exterior wall cladding and the assembly instructions of the manufacturer.

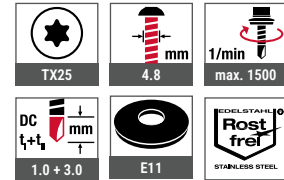
**Applications****Technical specifications****Certifications****Assembly instruction****Product in the online shop**

Order description	Length [mm]	Clamping thickness [mm]	PU [pieces]	Price/100 [EUR]	Article number	EAN
JT4-FR-4-4.8x19	19	0 - 9	1000		7381095300	4061245014241
<b>Sealing washer E 11, Ø 11 mm</b>						
JT4-FR-4-4.8x19 E11	19	0 - 6	500		3501968448	4061245027289

## Self-drilling screw JT4-FR-4-5.5



Cross references	Page
Sealing washers	126
Cordless screwdriver	
ASCM QSW	135
FR-tool plastic TX25	144

### Application range

- > Fastening aluminium corrugated profile sheet to aluminium substructure ≤ 3 mm
- > Fastening facade cladding to aluminium substructure

### Properties

- > A2 stainless steel
- > With truss head

### Notice

Please note the respective approval of the exterior wall cladding and the assembly instructions of the manufacturer.

### Applications



### Technical specifications

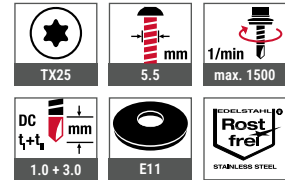

### Certifications



### Assembly instruction



### Product in the online shop



Order description	Length [mm]	Clamping thickness [mm]	PU [pieces]	Price/100 [EUR]	Article number	EAN
JT4-FR-4-5.5x19	19	0 - 11	1000		7381138300	4061245014234
<b>Sealing washer E 11, Ø 11 mm</b>						
JT4-FR-4-5.5x19 E11	19	0 - 11	500		3501869448	4061245027319

## Self-drilling screw JT4-FZ-6.5



### Application range

- > Fastening corrugated fibre cement sheets to timber substructures

### Properties

- > A2 stainless steel
- > Pre-assembled FZD sealing washer
- > A2 stainless steel washer
- > Screw wings save additional drilling into the corrugated slabs
- > Reduced forcing tension

### Notice

For the dimensioning and the use of fastening materials please note the manufacturer's instructions for use as well as the national approvals.

### Applications



### Technical specifications

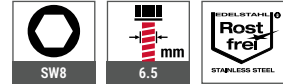

### Certifications



Cross references	Page
JT2-FZ-F-6.5x130-FZD	38
Cordless screwdriver	
ASCM QSW	135
Socket wrench insert SW8	141

### Assembly instruction



### Product in the online shop



Order description	Length [mm]	Thread length [mm]	PU [pieces]	Price/100 [EUR]	Article number	EAN
JT4-FZ-6.5x130 FZD	130	66	100		3515675400	4061245016061

## Self-drilling screw JT6-2H-Plus-5.5



Cross references	Page
Cordless screwdriver	
ASCM QSW	135
Socket wrench insert SW8	141

### Assembly instruction



### Product in the online shop



### Application range

- > Side lap stitching of profiled steel and aluminium sheets
- > Fastening profiled steel and aluminium sheets to cassette system walls
- > For high-strength steel substructures

### Characteristics

- > A4 stainless steel with hardened drill point
- > Stainless steel sealing washer
- > Pre-assembled sealing washer
- > With free spin zone under screw head for effective side lap stitching

### Applications

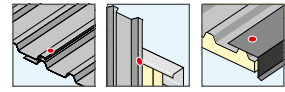

### Technical specifications

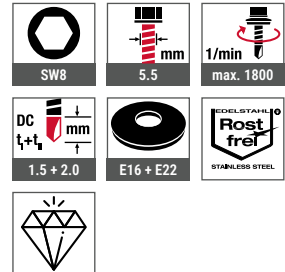

### Certifications



Order description	Length [mm]	Clamping thickness [mm]	PU [pieces]	Price/100 [EUR]	Article number	EAN
<b>Sealing washer E 16, Ø 16 mm</b>						
JT6-2H-Plus-5.5x25 E16	25	0 - 7	500		3592281991	4061245015521
<b>Sealing washer E 22, Ø 22 mm</b>						
JT6-2H-Plus-5.5x25 E22	25	0 - 7	500		3592283991	4061245050140

Also available in A2 stainless steel



Self-drilling screw  
JT3-2H-plus-5.5  
| Page 50

## Self-drilling screw JT6-6-5.5



### Application range

- > Fastening profiled steel and aluminium sheets to 1.5-4 mm steel substructures
- > For high-strength steel substructures

### Characteristics

- > A4 stainless steel with hardened steel drill point
- > Stainless steel sealing washer
- > Pre-assembled sealing washer

Cross references	Page
ORKAN storm washers	95
Cordless screwdriver	
ASCS QSW	135
Socket wrench insert SW8	141

### Applications



### Technical specifications

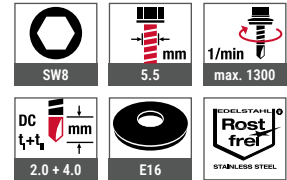

### Certifications

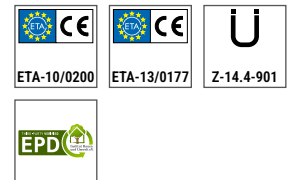

### Assembly instruction



### Product in the online shop



Order description	Length [mm]	Clamping thickness [mm]	PU [pieces]	Price/100 [EUR]	Article number	EAN
<b>Sealing washer E 16, Ø 16 mm</b>						
JT6-6-5.5x25-E16	25	0 - 7	500		3572281991	4061245015682

Further lengths upon request



Also available in A2 stainless steel



Self-drilling screw  
JT3-6-5.5  
| Page 54

## Self-drilling screw JT6-12-5.5



### Application range

- > Fastening profiled steel and aluminium sheets and sandwich panels to 4-10 mm steel substructures
- > Fastening aluminium profiled sheets to 4-12 mm aluminium substructures

### Characteristics

- > A4 stainless steel with hardened steel drill point
- > Stainless steel sealing washer
- > Pre-assembled sealing washer

Cross references	Page
ORKAN storm washers	95
Cordless screwdriver	
ASCS QSW	135
Socket wrench insert SW8	141

### Assembly instruction



### Product in the online shop



### Applications

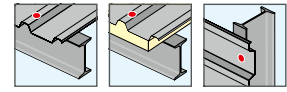

### Technical specifications

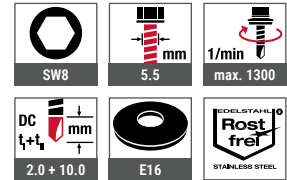

### Certifications

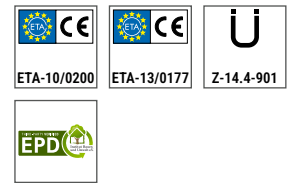

Order description	Length [mm]	Clamping thickness [mm]	PU [pieces]	Price/100 [EUR]	Article number	EAN
<b>Sealing washer E 16, Ø 16 mm</b>						
JT6-12-5.5x40-E16	40	0 - 11	500		3595681991	4061245015163

Further lengths upon request



Also available in A2 stainless steel



Self-drilling screw  
JT3-12-5.5  
| Page 58

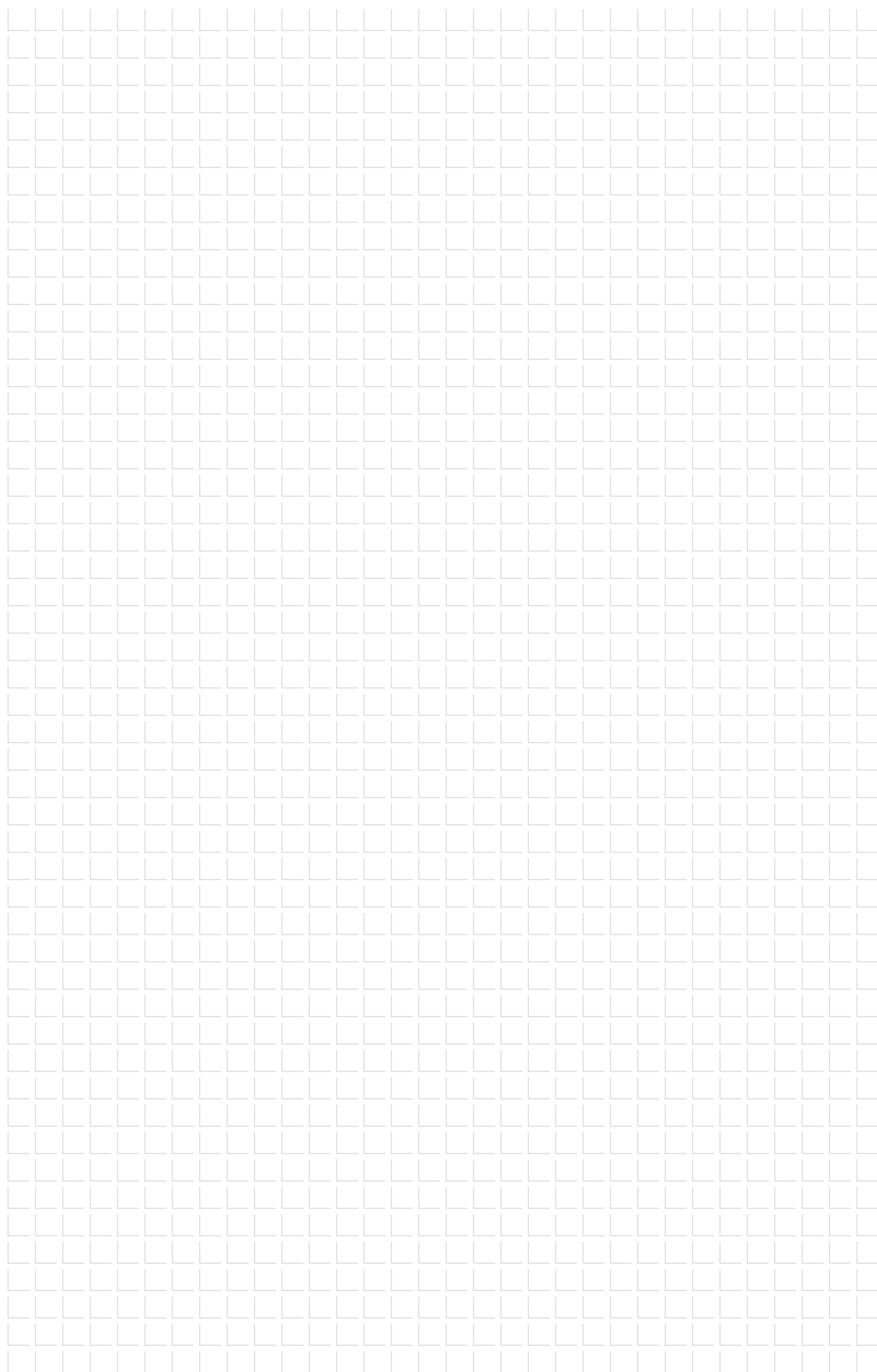

# Self-tapping screws

## Self-tapping screws with dog point or point

The EJOT self-tapping screws form the female thread in a pre-drilled hole without swarfs. They feature a coarse or fine pitch thread with dog point or point. The self-tapping screws are completed by a pre-assembled sealing washer. The EJOT self-tapping screws are all-purpose screws.

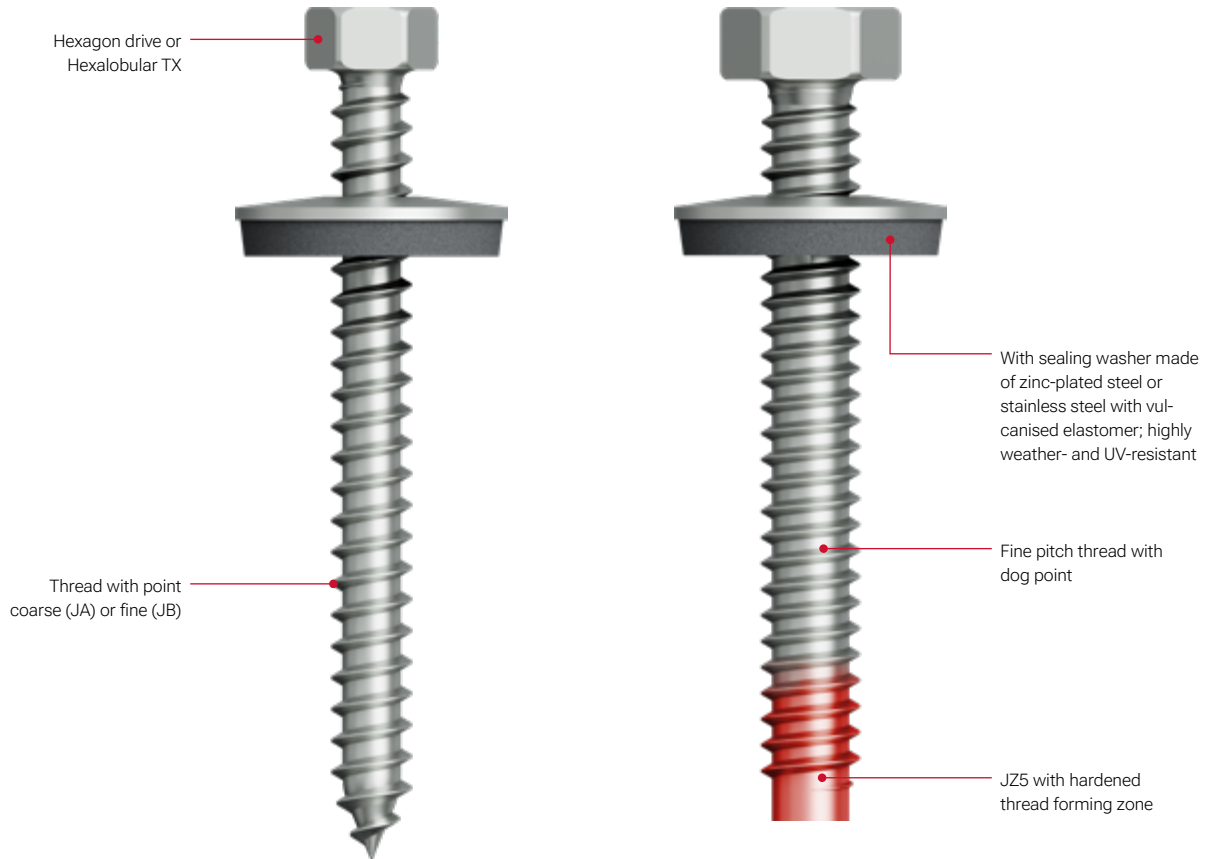

## Product overview self-tapping screws

	JA2/JB2/JZ2	JA3/JB3/JZ3	JA1/JZ1 CORREMAKS®	JZ5
Self-tapping screws with dog point or point				
Material	Case-hardened steel, protected against corrosion	A2 stainless steel	A8 stainless steel	A2 stainless steel with hardened thread forming zone
For components made of	Steel/aluminium/wood	Steel/aluminium/wood	Steel/aluminium/wood	Steel / Aluminium

# Selecting the self-tapping screw

Correct determination of screw length and drill hole diameter

## Determination of the screw length of self-tapping screws

The clamp thickness  $t_{fix}$  is the area of a self-tapping screw which can be used to connect two components. The components are clamped in this area (absorption and transfer of forces and loads in accordance with the respective technical approvals and assessments).

**Important: The clamp thickness does not equal the threaded part of a screw!**

Therefore:

- > The first thread turns of a self-tapping screw are **not** suitable for clamping.
- > For bi-met screws (JZ5), the screw point consists of a hardened steel part. This part is used exclusively for the assembly process of the screw and must not be used for clamping.
- > The clamping thicknesses of the self-tapping screws can be found in the tables on the product-specific pages.
- > The cutting off of screw points is not permitted!

The required clamping thickness of a self-tapping screw is calculated from the material thickness of the components to be clamped. For this, the thicknesses of components I and II, any intermediate layer and additional elements (including sealing washers, storm washers and load distributors) must be added together. It should be noted that the sealing washer thickness for screws with a pre-assembled sealing washer is already taken into account when specifying the clamping thickness.

The component thicknesses from the respective technical approvals and assessments must be observed!

If you have any questions about the selection of the suitable screw length for your application, please contact our application technology department.

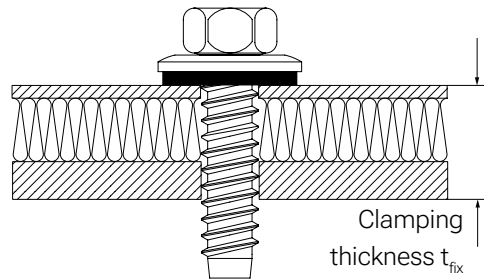

## Determining the drill hole diameter

Aluminium sheet, aluminium extrusion profile F22 to F 25  
( $R_m \geq 220 \text{ N/mm}^2 \leq 290 \text{ N/mm}^2$ )\*

Component thickness $t_{II}$ [mm]	up to 0.9	1.0 – 1.4	1.5 – 2.9	3.0 – 4.9	$\geq 5.0$
Drill hole diameter [mm]	4.0	4.0	4.5	5.0	5.3
EJOT screw type	JA Ø 6.5 / JB Ø 6.3			JZ Ø 6.3	

\* When fastening profiled aluminium sheet (component I) to steel substructures (component II) the drill hole diameters from the chart for steel substructures apply

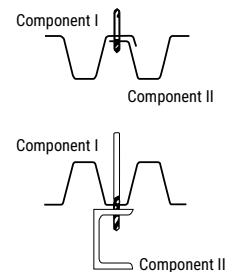

### Steel substructures according to ETA

Component thickness $t_{II}$ [mm]	0.63	0.75	0.88	1.00	1.13	1.25	1.50	2x 0.75	2x 0.88	2x 1.00	1.25 – 1.9	2.0 – 5.9	6.0 – 6.9	7.0 – 9.9	$\geq 10.0$	1.5 – 5.9	6.0 – 7.9	8.0 – 9.9	$\geq 10.0$
drill hole diameter [mm]	3.5	4.0	4.5	4.5	4.5	4.5	5.0	4.5	5.0	5.0	5.0	5.3	5.5	5.7	5.8	6.8	7.0	7.2	7.4
EJOT screw type	JA Ø 6.5 / JB Ø 6.3										JZ Ø 6.3				JZ Ø 8.0				

## Self-tapping screw JZ5-6.3



### Application range

- > Fastening profiled steel sheets and sandwich panels to steel substructures
- > For high-strength steel substructures

### Characteristics

- > A2 stainless steel with hardened thread forming zone
- > Stainless steel sealing washer
- > Pre-assembled sealing washer

### Applications

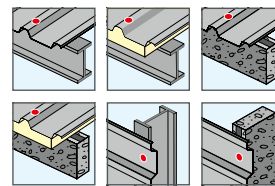

### Technical specifications

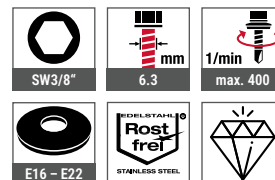

### Certifications

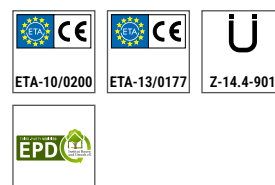

### Cross references

Cross references	Page
Drill hole chart	83
ORKAN storm washers	95
Cordless screwdriver	
ASCM QSW	135
Drill HSS	139
Socket wrench insert SW3/8"	141

### Assembly instruction



### Product in the online shop



Order description	Length [mm]	Clamping thickness [mm]	PU [pieces]	Price/100 [EUR]	Article number	EAN
<b>Sealing washer E 16, Ø 16 mm</b>						
JZ5-6.3x20 E16	20	0 - 9	500		3191011311	4061245073194
JZ5-6.3x25 E16	25	0 - 14	500		3191111311	4061245073224
JZ5-6.3x30 E16	30	0 - 19	500		3191211311	4061245073255
JZ5-6.3x40 E16	40	0 - 29	250		3191311311	4061245073286
JZ5-6.3x53 E16	53	0 - 41	250		3191411311	4061245073316
JZ5-6.3x63 E16	63	0 - 52	250		3191511311	4061245073347
JZ5-6.3x83 E16	83	21 - 72	250		3191611311	4061245073378
JZ5-6.3x93 E16	93	31 - 82	100		3191711311	4061245073408
JZ5-6.3x103 E16	103	41 - 92	100		3191811311	4061245074207
JZ5-6.3x113 E16	113	51 - 102	100		3191911311	4061245073460
JZ5-6.3x123 E16	123	61 - 112	100		3192011311	4061245099804
JZ5-6.3x133 E16	133	71 - 122	100		3192111311	4061245073521
JZ5-6.3x143 E16	143	81 - 132	100		3192211311	4061245076201
JZ5-6.3x153 E16	153	91 - 142	100		3192311311	4061245073552
JZ5-6.3x163 E16	163	101 - 152	100		3192411311	4061245073583
<b>NEW</b> JZ5-6.3x173 E16	173	101 - 162	100		3093011311	4061245126562
JZ5-6.3x183 E16	183	121 - 172	100		3192511311	4061245073613
<b>NEW</b> JZ5-6.3x193 E16	193	131 - 182	100		3093111311	4061245126593
JZ5-6.3x203 E16	203	141 - 192	100		3192611311	4061245073644
JZ5-6.3x223 E16	223	161 - 212	100		3192711311	4061245073675



	Order description	Length [mm]	Clamping thickness [mm]	PU [pieces]	Price/100 [EUR]	Article number	EAN
	JZ5-6.3x243 E16	243	181 – 232	100		3192811311	4061245073705
	JZ5-6.3x263 E16	263	201 – 252	100		3192911311	4061245073736
	<b>Sealing washer E 19, Ø 19 mm</b>						
	JZ5-6.3x20 E19	20	0 – 9	500		3191066311	4061245073200
	JZ5-6.3x25 E19	25	0 – 14	500		3191166311	4061245073231
	JZ5-6.3x30 E19	30	0 – 19	500		3191266311	4061245073262
	JZ5-6.3x40 E19	40	0 – 29	250		3191366311	4061245073293
	JZ5-6.3x53 E19	53	0 – 41	250		3191466311	4061245073323
	JZ5-6.3x63 E19	63	0 – 52	100		3191566311	4061245073354
	JZ5-6.3x83 E19	83	21 – 72	100		3191666311	4061245073385
	JZ5-6.3x93 E19	93	31 – 82	100		3191766311	4061245073415
	JZ5-6.3x103 E19	103	41 – 92	100		3191866311	4061245074221
	JZ5-6.3x113 E19	113	51 – 102	100		3191966311	4061245073477
	JZ5-6.3x123 E19	123	61 – 112	100		3192066311	3192066311
	JZ5-6.3x133 E19	133	71 – 122	100		3192166311	4061245073538
	JZ5-6.3x143 E19	143	81 – 132	100		3192266311	4061245076218
	JZ5-6.3x153 E19	153	91 – 142	100		3192366311	4061245073569
	JZ5-6.3x163 E19	163	101 – 152	100		3192466311	4061245073590
<b>NEW</b>	JZ5-6.3x173 E19	173	101 – 162	100		3093066311	4061245126579
	JZ5-6.3x183 E19	183	121 – 172	100		3192566311	4061245073620
<b>NEW</b>	JZ5-6.3x193 E19	193	131 – 182	100		3093166311	JZ5-6.3x193 E19
	JZ5-6.3x203 E19	203	141 – 192	100		3192666311	3192666311
	JZ5-6.3x223 E19	223	161 – 212	100		3192766311	4061245073682
	JZ5-6.3x243 E19	243	181 – 232	100		3192866311	4061245073712
	JZ5-6.3x263 E19	263	201 – 252	100		3192966311	3192966311
	<b>Sealing washer E 22, Ø 22 mm</b>						
	JZ5-6.3x20 E22	20	0 – 9	500		3191013311	4061245073217
	JZ5-6.3x25 E22	25	0 – 14	500		3191113311	4061245073248
	JZ5-6.3x30 E22	30	0 – 19	500		3191213311	4061245073279
	JZ5-6.3x40 E22	40	0 – 29	250		3191313311	4061245073309
	JZ5-6.3x53 E22	53	0 – 41	250		3191413311	3191413311
	JZ5-6.3x63 E22	63	0 – 52	100		3191513311	4061245073361
	JZ5-6.3x83 E22	83	21 – 72	100		3191613311	4061245073392
	JZ5-6.3x93 E22	93	31 – 82	100		3191713311	4061245073422
	JZ5-6.3x103 E22	103	41 – 92	100		3191813311	4061245074238
	JZ5-6.3x113 E22	113	51 – 102	100		3191913311	4061245073484
	JZ5-6.3x123 E22	123	61 – 112	100		3192013311	4061245073514
	JZ5-6.3x133 E22	133	71 – 122	100		3192113311	4061245073545
	JZ5-6.3x143 E22	143	81 – 132	100		3192213311	4061245076225
	JZ5-6.3x153 E22	153	91 – 142	100		3192313311	4061245073576
	JZ5-6.3x163 E22	163	101 – 152	100		3192413311	4061245073606
<b>NEW</b>	JZ5-6.3x173 E22	173	101 – 162	100		3093013311	4061245126586
	JZ5-6.3x183 E22	183	121 – 172	100		3192513311	4061245073637
<b>NEW</b>	JZ5-6.3x193 E22	193	131 – 182	100		3093113311	4061245126616
	JZ5-6.3x203 E22	203	141 – 192	100		3192613311	4061245073668
	JZ5-6.3x223 E22	223	161 – 212	100		3192713311	4061245073699
	JZ5-6.3x243 E22	243	181 – 232	100		3192813311	4061245073729
	JZ5-6.3x263 E22	263	201 – 252	100		3192913311	4061245073750

## Self-tapping screw JZ5-8.0



### Application range

- > Fastening profiled steel sheets and sandwich panels to steel substructures
- > Suitable for replacing screws with diameter 5.5 mm and 6.3 mm

### Characteristics

- > A2 stainless steel with hardened thread forming zone
- > Stainless steel sealing washer
- > Pre-assembled sealing washer

### Applications

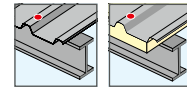

### Technical specifications

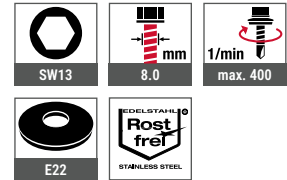

### Certifications

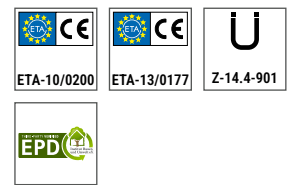

Cross references	Page
Drill hole chart	83
ORKAN storm washers	95
Cordless screwdriver	
ASCM QSW	135
Drill HSS	139
Socket wrench insert SW3/8"	141

### Assembly instruction



### Product in the online shop



Order description	Length [mm]	Clamping thickness [mm]	PU [pieces]	Price/100 [EUR]	Article number	EAN
<b>Sealing washer E 22, Ø 22 mm</b>						
JZ5-8.0x60 E22	60	0 – 43	250		3190653311	4061245062600
JZ5-8.0x80 E22	80	16 – 63	100		3190853311	4061245062617
JZ5-8.0x100 E22	100	36 – 83	100		3191053311	4061245062624
JZ5-8.0x150 E22	150	86 – 133	100		3191553311	4061245062631

**NEW** CORREMAKS® self-tapping screw JZ1-6.3

Cross references	Page
Drill hole chart	83
ORKAN storm washers	95
Cordless screwdriver	
ASCM QSW	135
Drill HSS	139
Socket wrench insert SW3/8"	141

**Application range**

- > Fastening profiled steel sheets and sandwich panels to steel substructures in highly corrosive environments
- > Suitable for replacing screws with diameter 5.5 mm

**Characteristics**

- > A8 stainless steel – 1,4529
- > Stainless steel sealing washer
- > Pre-assembled sealing washer
- > Highest corrosion protection class

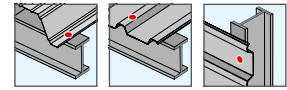
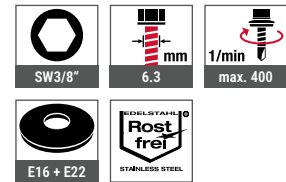
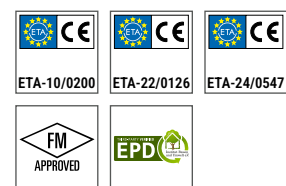
**Applications****Technical specifications****Certifications****Assembly instruction****Product in the online shop**

Order description	Length [mm]	Clamping thickness [mm]	PU [pieces]	Price/100 [EUR]	Article number	EAN
JZ1-6.3x22	22	0 – 10	500		3111200319	4061245028088
JZ1-6.3x54	54	0 – 42	250		3111500319	4061245050874
JZ1-6.3x70	70	6 – 58	250		3111700319	4061245050850
<b>Sealing washer E 16, Ø 16 mm</b>						
JZ1-6.3x22 E16	22	0 – 7	500		3111211319	4061245017549
JZ1-6.3x54 E16	54	0 – 39	250		3111511319	4061245017518
JZ1-6.3x70 E16	70	3 – 55	250		3111711319	4061245017495
JZ1-6.3x125 E16	125	60 – 110	100		3112411319	4061245017426
<b>Sealing washer E 22, Ø 22 mm</b>						
JZ1-6.3x22 E22	22	0 – 7	500		3111213319	4061245050904

**NEW** CORREMAKS® self-tapping screw JA1-6.5



**Application range**

- > Side lap stitching of profiled steel sheets in highly corrosive environments
- > Fastening profiled steel sheets and sandwich panels to timber substructures in highly corrosive environments

**Characteristics**

- > A8 stainless steel – 1,4529
- > Stainless steel sealing washer
- > Pre-assembled sealing washer
- > Highest corrosion protection class

**Applications**

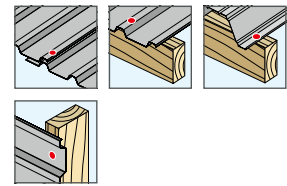

**Technical specifications**

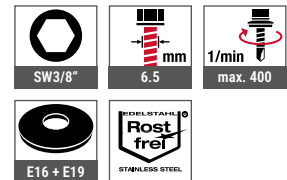

**Certifications**



Cross references	Page
Drill hole chart	83
ORKAN storm washers	95
Cordless screwdriver	
ASCM QSW	135
Drill HSS	139
Socket wrench insert SW3/8"	141

**Assembly instruction**



**Product in the online shop**



Order description	Length [mm]	Height component I [mm]	PU [pieces]	Price/100 [EUR]	Article number	EAN
JA1-6.5x22	22	-	500		3113200319	4061245050775
JA1-6.5x38	38	-	500		3113400319	4061245050768
JA1-6.5x64	64	0 – 14	250		3113800319	4061245050751
JA1-6.5x115	115	40 – 65	200		3114300319	4061245050744
JA1-6.5x145	145	70 – 95	200		3114600319	4061245077918
<b>Sealing washer E 16, Ø 16 mm</b>						
JA1-6.5x22 E16	22	-	500		3113211319	4061245017372
JA1-6.5x38 E16	38	-	500		3113411319	4061245017365
JA1-6.5x64 E16	64	0 – 11	250		3113811319	4061245017358
JA1-6.5x115 E16	115	37 – 62	100		3114311319	4061245017341
JA1-6.5x145 E16	145	67 – 92	100		3114611319	4061245017334
<b>Sealing washer E 19, Ø 19 mm</b>						
JA1-6.5x22 E19	22	-	500		3113212319	4061245077901

## Self-tapping screw JZ3-S-6.3



### Application range

- > For fixing metal sections, timber, treads, platforms and balcony slabs to steel or aluminium substructures

### Characteristics

- > A2 stainless steel
- > Countersunk head

Cross references	Page
Drill hole chart	83
Cordless screwdriver	
ASCM QSW	135
Drill HSS	139
Bit hexalobular TX30	142

### Applications



### Technical specifications

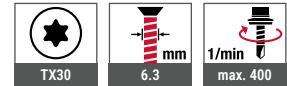

### Certifications

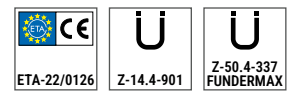

### Assembly instruction



### Product in the online shop



Order description	Length [mm]	PU [pieces]	Price/100 [EUR]	Article number	EAN
JZ3-S-6.3x19	19	500		3029400311	4061245018430
JZ3-S-6.3x25	25	500		3029500311	4061245018423
JZ3-S-6.3x35	35	500		3121700301	4061245017327
JZ3-S-6.3x64	64	250		3029600311	4061245018416

## Self-tapping screw JA3-LT-4.9



### Application range

- > For fixing metal sections to timber or aluminium substructures ≤ 2 mm

### Characteristics

- > A2 stainless steel
- > Pan head

### Applications

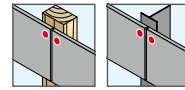

### Technical specifications

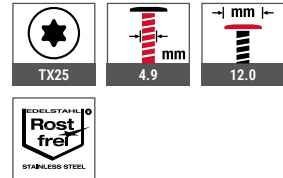

### Certifications



Cross references	Page
Cordless screwdriver	
ASCM QSW	135
Drill HSS	139
Bit hexalobular TX25	142

### Assembly instruction



### Product in the online shop



Order description	Length [mm]	PU [pieces]	Price/100 [EUR]	Article number	EAN
JA3-LT-4.9x25 TX25	25	500		3243250312	4061245105710
JA3-LT-4.9x38 TX25	38	500		3243380312	4061245105727

## Self-tapping screw JA3-S-6.5



### Application range

- > For fixing metal sections to timber substructures, aluminium substructures ≤ 3 mm or steel substructures ≤ 2 mm
- > For fixing treads, platform and balcony slabs to timber or aluminium substructures

### Characteristics

- > A2 stainless steel
- > Countersunk head
- > With full thread

Cross references	Page
Drill hole chart	83
Cordless screwdriver	
ASCM QSW	135
Drill HSS	139
Bit hexalobular TX 30	142

### Applications

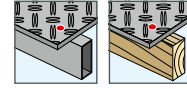

### Technical specifications

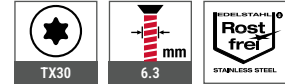

### Certifications



### Assembly instruction



### Product in the online shop



Order description	Length [mm]	PU [pieces]	Price/100 [EUR]	Article number	EAN
JA3-S-6.5x35	35	500		3029800311	4061245018409

## Self-tapping screw JB3-7.2



### Application range

- > Repair screw for covering faulty drill holes

### Characteristics

- > A2 stainless steel
- > Stainless steel sealing washer
- > Pre-assembled sealing washer

### Technical specifications

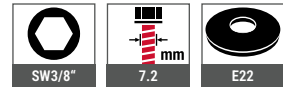

### Certifications



Cross references	Page
Cordless screwdriver	
ASCM QSW	135
Drill HSS	139
Socket wrench insert SW3/8"	141

### Assembly instruction



### Product in the online shop



Order description	Length [mm]	PU [pieces]	Price/100 [EUR]	Article number	EAN
<b>Sealing washer E 22, Ø 22 mm</b>					
JB3-7.2x19 E22	19	100		3189113311	4061245016689

## Clamping screw RLS 25

**Application range**

- > For side lap stitching of profiled plastic sheets
- > Fastening of chamfered parts to profiled plastic sheets

**Characteristics**

- > A2 stainless steel screw
- > Stainless steel sealing washer
- > Pre-assembled sealing washer
- > EPDM sealing sleeve with brass thread insert

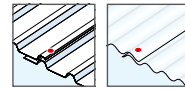
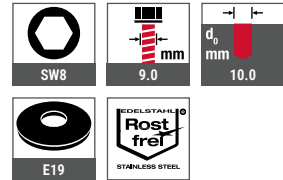
**Applications****Technical specifications****Certifications****Cross references**

	Page
Cordless screwdriver	
ASCM QSW	135
Socket wrench insert SW8	141

**Product in the online shop**

Order description	Length [mm]	Thread type Screw	PU [pieces]	Price/100 [EUR]	Article number	EAN
<b>Sealing washer E 19, Ø 19 mm</b>						
RLS-25-8.0x25 E19	25.0	M5	250		3110000139	4061245017617

# ORKAN Storm Washers

Increased installation reliability, high form stability and optimum load transmission for crown fixings

## Requirements

ORKAN storm washers are used for a consistent load distribution and load transmission of the crown fixing of trapezoidal profiled sheet or sandwich panel constructions. This is guaranteed by the pronounced reinforcement beads of the ORKAN storm washers.

As a so-called second insulation level, the storm washer permanently buffers the fixed size between upper substructure edge and screw head. The sheet metal crown is often slightly convex or concave. In order to compensate these tolerances, a soft closed-cell rubber is ideal. No bridging arises where moisture can enter up to the fastener shank and thus the inside of the building.

The permanent compression required for the lasting watertightness of this cellular rubber is minimal and the deformation of a thin-walled trapezoidal profiled sheet can be prevented during installation.

## Installation reliability

EJOT ORKAN storm washers also promote to a reliable installation because the installer can use them as a plate drill jig when placing the storm washer. It always hits the middle of the crown. Furthermore, the surface of the profile element is protected against scratches during the fastening process.

The ORKAN storm washer provides an increased clamping force on the component, without plastic deformation. The increased load due to the use of EJOT ORKAN storm washers is documented in various building authorities test certificates (type statistics) for trapezoidal aluminium profiles.

## Notice

Please note that we can only accept warranty and liability claims regarding EJOT ORKAN storm washers when used in combination with EJOT screws. If you have any questions in this regard, please do not hesitate to contact us. Thank you for your understanding.

In addition to the storm washers listed in the order tables, we also offer combinations of standard shapes

and colours. These are available at the MSRP of the comparable storm washers in the catalogue, but only in packaging units of 500 pieces. Please note that this might result in longer delivery times.

## Standard colours (similar RAL colours)

1015	2001	3000	3003	3009	3011
3016	5010	5015	6003	6005	6009
6011	6020	7016	7022	7032	7035
7037	7042	8004	8011	8012	8014
8016	8017	8019	8024	9002	9005
9006	9007	9010			

## Standard shapes

Storm washer profiles	Storm washer profiles	Storm washer profiles
20-34	31-37	41-32
21-16	32-25	41-39
21-25	34-50	41-50
23-33	35-23	53-36
26-15	35-47	55-32
26-27	36-32	W24
26-34	36-40	W30
26-50	41-16	W43
31-31	41-24	W48

## Special storm washers

Version	Additional cost /	MSRP [EUR]
All storm washer shapes not mentioned in the catalogue are special storm washers	100 pcs.	33,20

## ORKAN storm washer trapezoidal



Cross references	Page
Self-drilling screw JF3-Plus-6.8	46
Self-drilling screw JT3-2-6.5	52
Self-drilling screw JT3-6-5.5	54
Self-drilling screw JT3-12-5.5	58
Self-drilling screw JT3-18-5.5	61
Concrete screw JC6-D-7.5	67
Self-tapping screw JZ5-6.3	84

### Application range

- > Crown fixing of trapezoidal sheets and sandwich panels
- > Crown fixing of light diffusing panels

### Properties

- > Optimised reinforcement beads
- > Secure waterproofing
- > Aluminium alloy mill finish, coloured (RAL)

### Advantages

- > Increased installation reliability
- > High dimensional stability
- > Optimum load transmission
- > Sophisticated fastening system in combination with self-drilling and self-tapping screws

### Notice

Only use screws with 16 mm and 19 mm washer diameter. For determination of the clamp thickness please take the storm washer into account with 3 mm. The guidelines and installation instructions given by the profile and panel manufacturer are to be observed. Storm washers which are not mentioned are special storm washers. Please note surcharges. Storm washers are to be stored in a dry place until installation.

### Applications

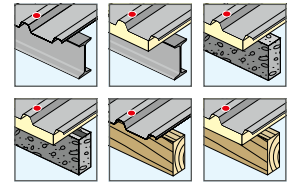

### Technical specifications



### Certifications



### Product in the online shop



Order description	Width of storm washer [mm]	Inclination angle [°]	Crown width [mm]	PU [pieces]	Price/100 [EUR]	Article number	EAN
ORKAN storm washer 21-16 mill finish	21	16	20	500		3046600110	4061245018362
ORKAN storm washer 21-16 mill finish VE100	21	16	20	100		3076600110	4061245082264
ORKAN storm washer 21-16 alu-RAL 3009	21	16	20	500		3046657119	4061245030340
ORKAN storm washer 21-16 Alu-RAL 3009 VE100	21	16	20	100		3076657119	4061245082271
ORKAN storm washer 21-16 alu-RAL 7016	21	16	20	500		3052116025	4061245029702
ORKAN storm washer 21-16 Alu-RAL 7016 VE100	21	16	20	100		3072116025	4061245082288
ORKAN storm washer 21-16 alu-RAL 8004	21	16	20	500		3052116043	4061245029696
ORKAN storm washer 21-16 Alu-RAL 8004 VE100	21	16	20	100		3072116043	4061245082318
ORKAN storm washer 21-16 alu-RAL 8012	21	16	20	500		3046640119	4061245030357
ORKAN storm washer 21-16 Alu-RAL 8012 VE100	21	16	20	100		3076640119	4061245082325
ORKAN storm washer 21-16 alu-RAL 9002	21	16	20	500		3046682119	4061245030326
ORKAN storm washer 21-16 Alu-RAL 9002 VE100	21	16	20	100		3076682119	4061245082332
ORKAN storm washer 21-16 alu-RAL 9006	21	16	20	500		3046684119	4061245030319
ORKAN storm washer 21-16 Alu-RAL 9006 VE100	21	16	20	100		3076684119	4061245082349
ORKAN storm washer 21-16 alu-RAL 9007	21	16	20	500		3052116220	4061245029672
ORKAN storm washer 21-16 Alu-RAL 9007 VE100	21	16	20	100		3072116220	4061245082356
ORKAN storm washer 21-25 mill finish	21	25	20	500		3052125000	4061245018270
ORKAN storm washer 21-25 mill finish VE100	21	25	20	100		3072125000	4061245086194
ORKAN storm washer 21-25 alu-RAL 3009	21	25	20	500		3052125057	4061245029627
ORKAN storm washer 21-25 Alu-RAL 3009 VE100	21	25	20	100		3072125057	4061245086477
ORKAN storm washer 21-25 alu-RAL 7016	21	25	20	500		3052125025	4061245029658
ORKAN storm washer 21-25 Alu-RAL 7016 VE100	21	25	20	100		3072125025	4061245086200
ORKAN storm washer 21-25 alu-RAL 8004	21	25	20	500		3052125043	4061245029634
ORKAN storm washer 21-25 Alu-RAL 8004 VE100	21	25	20	100		3072125043	4061245086224
ORKAN storm washer 21-25 alu-RAL 8012	21	25	20	500		3052125040	4061245029641





Order description	Width of storm washer [mm]	Inclination angle [°]	Crown width [mm]	PU [pieces]	Price/100 [EUR]	Article number	EAN
ORKAN storm washer 21-25 Alu-RAL 8012 VE100	21	25	20	100		3072125040	4061245086187
ORKAN storm washer 21-25 alu-RAL 9002	21	25	20	500		3052125082	4061245029597
ORKAN storm washer 21-25 Alu-RAL 9002 VE100	21	25	20	100		3072125082	4061245086231
ORKAN storm washer 21-25 alu-RAL 9006	21	25	20	500		3052125084	4061245029580
ORKAN storm washer 21-25 Alu-RAL 9006 VE100	21	25	20	100		3072125084	4061245086217
ORKAN storm washer 21-25 alu-RAL 9007	21	25	20	500		3052125220	4061245029573
ORKAN storm washer 21-25 Alu-RAL 9007 VE100	21	25	20	100		3072125220	4061245086248
ORKAN storm washer 23-33 mill finish	23	33	22	500		3052333000	4061245018263
ORKAN storm washer 23-33 mill finish VE100	23	33	22	100		3072333000	4061245046280
ORKAN storm washer 23-33 alu-RAL 7016	23	33	22	500		3052333025	4061245058078
ORKAN storm washer 23-33 Alu-RAL 7016 VE100	23	33	22	100		3072333025	4061245061658
ORKAN storm washer 23-33 alu-RAL 9002	23	33	22	500		3052333082	4061245058030
ORKAN storm washer 23-33 Alu-RAL 9002 VE100	23	33	22	100		3072333082	4061245061665
ORKAN storm washer 26-15 mill finish	26	15	25	500		3046900110	4061245018348
ORKAN storm washer 26-15 mill finish VE100	26	15	25	100		3076900110	4061245044996
ORKAN storm washer 26-15 alu-RAL 3009	26	15	25	500		3046957119	4061245030128
ORKAN storm washer 26-15 Alu-RAL 3009 VE100	26	15	25	100		3076957119	4061245017914
ORKAN storm washer 26-15 alu-RAL 7016	26	15	25	500		3052615025	4061245029504
ORKAN storm washer 26-15 Alu-RAL 7016 VE100	26	15	25	100		3072615025	4061245018126
ORKAN storm washer 26-15 alu-RAL 7035	26	15	25	500		3052615075	4061245029443
ORKAN storm washer 26-15 Alu-RAL 7035 VE100	26	15	25	100		3072615075	4061245046327
ORKAN storm washer 26-15 alu-RAL 8004	26	15	25	500		3052615043	4061245029474
ORKAN storm washer 26-15 Alu-RAL 8004 VE100	26	15	25	100		3072615043	4061245045009
ORKAN storm washer 26-15 alu-RAL 8012	26	15	25	500		3046940119	4061245030135
ORKAN storm washer 26-15 Alu-RAL 8012 VE100	26	15	25	100		3076940119	4061245017921
ORKAN storm washer 26-15 alu-RAL 9002	26	15	25	500		3046982119	4061245030098
ORKAN storm washer 26-15 Alu-RAL 9002 VE100	26	15	25	100		3076982119	4061245017907
ORKAN storm washer 26-15 alu-RAL 9006	26	15	25	500		3046984119	4061245030081
ORKAN storm washer 26-15 Alu-RAL 9006 VE100	26	15	25	100		3076984119	4061245017891
ORKAN storm washer 26-15 alu-RAL 9007	26	15	25	500		3052615220	4061245029399
ORKAN storm washer 26-15 Alu-RAL 9007 VE100	26	15	25	100		3072615220	4061245018119
ORKAN storm washer 26-27 mill finish	26	27	25	500		3047000110	4061245018331
ORKAN storm washer 26-27 mill finish VE100	26	27	25	100		3077000110	4061245017884
ORKAN storm washer 26-27 alu-RAL 3000	26	27	25	500		3047087119	4061245029887
ORKAN storm washer 26-27 Alu-RAL 3000 VE100	26	27	25	100		3077087119	4061245046365
ORKAN storm washer 26-27 alu-RAL 3009	26	27	25	500		3047057119	4061245029986
ORKAN storm washer 26-27 Alu-RAL 3009 VE100	26	27	25	100		3077057119	4061245017846
ORKAN storm washer 26-27 alu-RAL 6005	26	27	25	500		3052627243	4061245029306
ORKAN storm washer 26-27 Alu-RAL 6005 VE100	26	27	25	100		3072627243	4061245018096
ORKAN storm washer 26-27 alu-RAL 6011	26	27	25	500		3047066119	4061245029955
ORKAN storm washer 26-27 Alu-RAL 6011 VE100	26	27	25	100		3077066119	4061245045108
ORKAN storm washer 26-27 alu-RAL 7016	26	27	25	500		3047025119	4061245030036
ORKAN storm washer 26-27 Alu-RAL 7016 VE100	26	27	25	100		3077025119	4061245017877
ORKAN storm washer 26-27 alu-RAL 7035	26	27	25	500		3047075119	4061245029948
ORKAN storm washer 26-27 Alu-RAL 7035 VE100	26	27	25	100		3077075119	4061245045115
ORKAN storm washer 26-27 alu-RAL 8004	26	27	25	500		3047043119	4061245030005
ORKAN storm washer 26-27 Alu-RAL 8004 VE100	26	27	25	100		3077043119	4061245017853
ORKAN storm washer 26-27 alu-RAL 8011	26	27	25	500		3047078119	4061245029931





Order description	Width of storm washer [mm]	Inclination angle [°]	Crown width [mm]	PU [pieces]	Price/100 [EUR]	Article number	EAN
ORKAN storm washer 26-27 Alu-RAL 8011 VE100	26	27	25	100		3077078119	4061245017839
ORKAN storm washer 26-27 alu-RAL 8012	26	27	25	500		3047040119	4061245030012
ORKAN storm washer 26-27 Alu-RAL 8012 VE100	26	27	25	100		3077040119	4061245017860
ORKAN storm washer 26-27 alu-RAL 8014	26	27	25	500		3047079119	4061245029924
ORKAN storm washer 26-27 Alu-RAL 8014 VE100	26	27	25	100		3077079119	4061245045122
ORKAN storm washer 26-27 alu-RAL 9002	26	27	25	500		3047082119	4061245029917
ORKAN storm washer 26-27 Alu-RAL 9002 VE100	26	27	25	100		3077082119	4061245017822
ORKAN storm washer 26-27 alu-RAL 9006	26	27	25	500		3047084119	4061245029900
ORKAN storm washer 26-27 Alu-RAL 9006 VE100	26	27	25	100		3077084119	4061245017815
ORKAN storm washer 26-27 alu-RAL 9007	26	27	25	500		3052627220	4061245029313
ORKAN storm washer 26-27 Alu-RAL 9007 VE100	26	27	25	100		3072627220	4061245018102
ORKAN storm washer 26-34 mill finish	26	34	25	500		3052634000	4061245018256
ORKAN storm washer 26-34 mill finish VE100	26	34	25	100		3072634000	4061245046372
ORKAN storm washer 26-34 alu-RAL 7016	26	34	25	500		3052634025	4061245029290
ORKAN storm washer 26-34 Alu-RAL 7016 VE100	26	34	25	100		3072634025	4061245045139
ORKAN storm washer 26-34 alu-RAL 8004	26	34	25	500		3052634043	4061245029276
ORKAN storm washer 26-34 Alu-RAL 8004 VE100	26	34	25	100		3072634043	4061245046389
ORKAN storm washer 26-34 alu-RAL 8012	26	34	25	500		3052634040	4061245029283
ORKAN storm washer 26-34 Alu-RAL 8012 VE100	26	34	25	100		3072634040	4061245046396
ORKAN storm washer 26-34 alu-RAL 9002	26	34	25	500		3052634082	4061245029238
ORKAN storm washer 26-34 Alu-RAL 9002 VE100	26	34	25	100		3072634082	4061245046402
ORKAN storm washer 26-34 alu-RAL 9006	26	34	25	500		3052634084	4061245029221
ORKAN storm washer 26-34 Alu-RAL 9006 VE100	26	34	25	100		3072634084	4061245061689
ORKAN storm washer 26-34 alu-RAL 9007	26	34	25	500		3052634220	4061245029177
ORKAN storm washer 26-34 Alu-RAL 9007 VE100	26	34	25	100		3072634220	4061245061696
ORKAN storm washer 26-50 mill finish	26	50	25	500		3052650000	4061245018249
ORKAN storm washer 26-50 mill finish VE100	26	50	25	100		3072650000	4061245046419
ORKAN storm washer 26-50 alu-RAL 7016	26	50	25	500		3052650025	4061245029153
ORKAN storm washer 26-50 Alu-RAL 7016 VE100	26	50	25	100		3072650025	4061245045153
ORKAN storm washer 26-50 alu-RAL 8012	26	50	25	500		3052650040	4061245029139
ORKAN storm washer 26-50 Alu-RAL 8012 VE100	26	50	25	100		3072650040	4061245061702
ORKAN storm washer 31-31 mill finish	31	31	30	500		3053132000	4061245084756
ORKAN storm washer 31-31 mill finish VE100	31	31	30	100		3073132000	4061245084817
ORKAN storm washer 31-31 alu-RAL 7016	31	31	30	500		3053131025	4061245084732
ORKAN storm washer 31-31 Alu-RAL 7016 VE100	31	31	30	100		3073131025	4061245084794
ORKAN storm washer 32-25 mill finish	32	25	31	500		3053124000	4061245082479
ORKAN storm washer 32-25 mill finish VE100	32	25	31	100		3073124000	4061245082486
ORKAN storm washer 32-25 RAL 3000	32	25	31	500		3053124087	4061245084510
ORKAN storm washer 32-25 RAL 3000 VE 100	32	25	31	100		3073124087	4061245093086
ORKAN storm washer 32-25 alu-RAL 3009	32	25	31	500		3053124057	4061245082493
ORKAN storm washer 32-25 Alu-RAL 3009 VE100	32	25	31	100		3073124057	4061245082509
ORKAN storm washer 32-25 alu-RAL 7016	32	25	31	500		3053124025	4061245082516
ORKAN storm washer 32-25 Alu-RAL 7016 VE100	32	25	31	100		3073124025	4061245082523
ORKAN storm washer 32-25 alu-RAL 7035	32	25	31	500		3053124075	4061245082530
ORKAN storm washer 32-25 Alu-RAL 7035 VE100	32	25	31	100		3073124075	4061245082547
ORKAN storm washer 32-25 alu-RAL 8004	32	25	31	500		3053225043	4061245028705
ORKAN storm washer 32-25 Alu-RAL 8004 VE100	32	25	31	100		3073225043	4061245082554
ORKAN storm washer 32-25 alu-RAL 8012	32	25	31	500		3053124040	4061245082561





Order description	Width of storm washer [mm]	Inclination angle [°]	Crown width [mm]	PU [pieces]	Price/100 [EUR]	Article number	EAN
ORKAN storm washer 32-25 Alu-RAL 8012 VE100	32	25	31	100		3073124040	4061245082578
ORKAN storm washer 32-25 alu-RAL 9002	32	25	31	500		3053124082	4061245082608
ORKAN storm washer 32-25 Alu-RAL 9002 VE100	32	25	31	100		3073124082	4061245082615
ORKAN storm washer 32-25 alu-RAL 9006	32	25	31	500		3053124084	4061245082622
ORKAN storm washer 32-25 Alu-RAL 9006 VE100	32	25	31	100		3073124084	4061245082639
ORKAN storm washer 32-25 alu-RAL 9007	32	25	31	500		3053124220	4061245082646
ORKAN storm washer 32-25 Alu-RAL 9007 VE100	32	25	31	100		3073124220	4061245082653
ORKAN storm washer 35-47 mill finish	35	47	34	500		3053547000	4061245018195
ORKAN storm washer 35-47 mill finish VE100	35	47	34	100		3073547000	4061245046501
ORKAN storm washer 35-47 alu-RAL 7016	35	47	34	500		3053547025	4061245028477
ORKAN storm washer 35-47 Alu-RAL 7016 VE100	35	47	34	100		3073547025	4061245018027
ORKAN storm washer 35-47 alu-RAL 8012	35	47	34	500		3053547040	4061245028460
ORKAN storm washer 35-47 Alu-RAL 8012 VE100	35	47	34	100		3073547040	4061245018010
ORKAN storm washer 35-47 alu-RAL 9002	35	47	34	500		3053547082	4061245028385
ORKAN storm washer 35-47 Alu-RAL 9002 VE100	35	47	34	100		3073547082	4061245018003
ORKAN storm washer 35-47 alu-RAL 9006	35	47	34	500		3053547084	4061245028378
ORKAN storm washer 35-47 Alu-RAL 9006 VE100	35	47	34	100		3073547084	4061245046839
ORKAN storm washer 35-47 alu-RAL 9007	35	47	34	500		3053547220	4061245028347
ORKAN storm washer 35-47 Alu-RAL 9007 VE100	35	47	34	100		3073547220	4061245093307
ORKAN storm washer 36-32 mill finish	36	32	35	500		3053632000	4061245074436
ORKAN storm washer 36-32 mill finish VE100	36	32	35	100		3073632000	4061245073828
ORKAN storm washer 36-32 alu-RAL 3009	36	32	35	500		3053632057	4061245075174
ORKAN storm washer 36-32 Alu-RAL 3009 VE100	36	32	35	100		3073632057	4061245093314
ORKAN storm washer 36-32 alu-RAL 7016	36	32	35	500		3053632220	4061245105703
ORKAN storm washer 36-32 Alu-RAL 7016 VE100	36	32	35	100		3073632220	4061245105802
ORKAN storm washer 36-32 alu-RAL 8012	36	32	35	500		3053632025	4061245075181
ORKAN storm washer 36-32 Alu-RAL 8012 VE100	36	32	35	100		3073632025	4061245093321
ORKAN storm washer 36-32 alu-RAL 9007	36	32	35	500		3053632040	4061245073118
ORKAN storm washer 36-32 Alu-RAL 9007 VE100	36	32	35	100		3073632040	4061245073842
ORKAN storm washer 36-40 mill finish	36	40	35	500		3053538000	4061245018201
ORKAN storm washer 36-40 mill finish VE100	36	40	35	100		3073538000	4061245082660
ORKAN storm washer 36-40 alu-RAL 7016	36	40	35	500		3053541025	4061245028552
ORKAN storm washer 36-40 Alu-RAL 7016 VE100	36	40	35	100		3073541025	4061245082677
ORKAN storm washer 36-40 alu-RAL 8004	36	40	35	500		3053541043	4061245041162
ORKAN storm washer 36-40 Alu-RAL 8004 VE100	36	40	35	100		3073541043	4061245082684
ORKAN storm washer 36-40 alu-RAL 8012	36	40	35	500		3053541040	4061245041179
ORKAN storm washer 36-40 Alu-RAL 8012 VE100	36	40	35	100		3073541040	4061245082691
ORKAN storm washer 36-40 alu-RAL 9002	36	40	35	500		3053541082	4061245041155
ORKAN storm washer 36-40 Alu-RAL 9002 VE100	36	40	35	100		3073541082	4061245082707
ORKAN storm washer 36-40 alu-RAL 9006	36	40	35	500		3053541084	4061245057835
ORKAN storm washer 36-40 Alu-RAL 9006 VE100	36	40	35	100		3073541084	4061245082714
ORKAN storm washer 41-16 mill finish	41	16	40	500		3046200110	4061245018379
ORKAN storm washer 41-16 mill finish VE100	41	16	40	100		3076200110	4061245045221
ORKAN storm washer 41-16 alu-RAL 7016	41	16	40	500		3046225119	4061245030524
ORKAN storm washer 41-16 Alu-RAL 7016 VE100	41	16	40	100		3076225119	4061245045238
ORKAN storm washer 41-16 alu-RAL 8012	41	16	40	500		3046240119	4061245030494
ORKAN storm washer 41-16 Alu-RAL 8012 VE100	41	16	40	100		3076240119	4061245045245
ORKAN storm washer 41-16 alu-RAL 9002	41	16	40	500		3046282119	4061245030425





Order description	Width of storm washer [mm]	Inclination angle [°]	Crown width [mm]	PU [pieces]	Price/100 [EUR]	Article number	EAN
ORKAN storm washer 41-16 Alu-RAL 9002 VE100	41	16	40	100		3076282119	4061245017945
ORKAN storm washer 41-16 alu-RAL 9006	41	16	40	500		3046284119	4061245030418
ORKAN storm washer 41-16 Alu-RAL 9006 VE100	41	16	40	100		3076284119	4061245045252
ORKAN storm washer 41-32 mill finish	41	32	40	500		3049200110	4061245018300
ORKAN storm washer 41-32 mill finish VE100	41	32	40	100		3079200110	4061245017761
ORKAN storm washer 41-32 alu-RAL 1015	41	32	40	500		3049291119	4061245029801
ORKAN storm washer 41-32 Alu-RAL 1015 VE100	41	32	40	100		3079291119	4061245061726
ORKAN storm washer 41-32 alu-RAL 3000	41	32	40	500		3049287119	4061245029818
ORKAN storm washer 41-32 Alu-RAL 3000 VE100	41	32	40	100		3079287119	4061245061733
ORKAN storm washer 41-32 alu-RAL 3009	41	32	40	500		3049257119	4061245029849
ORKAN storm washer 41-32 Alu-RAL 3009 VE100	41	32	40	100		3079257119	4061245017723
ORKAN storm washer 41-32 alu-RAL 3011	41	32	40	500		3054132237	4061245041148
ORKAN storm washer 41-32 Alu-RAL 3011 VE100	41	32	40	100		3074132237	4061245045269
ORKAN storm washer 41-32 alu-RAL 6005	41	32	40	500		3054132243	4061245028132
ORKAN storm washer 41-32 Alu-RAL 6005 VE100	41	32	40	100		3074132243	4061245017983
ORKAN storm washer 41-32 alu-RAL 6011	41	32	40	500		3049266119	4061245025124
ORKAN storm washer 41-32 Alu-RAL 6011 VE100	41	32	40	100		3079266119	4061245045276
ORKAN storm washer 41-32 alu-RAL 6020	41	32	40	500		3049234119	4061245025179
ORKAN storm washer 41-32 Alu-RAL 6020 VE100	41	32	40	100		3079234119	4061245045283
ORKAN storm washer 41-32 alu-RAL 7016	41	32	40	500		3049225119	4061245025186
ORKAN storm washer 41-32 Alu-RAL 7016 VE100	41	32	40	100		3079225119	4061245017754
ORKAN storm washer 41-32 alu-RAL 7035	41	32	40	500		3049275119	4061245025117
ORKAN storm washer 41-32 Alu-RAL 7035 VE100	41	32	40	100		3079275119	4061245017716
ORKAN storm washer 41-32 alu-RAL 8004	41	32	40	500		3049243119	4061245025148
ORKAN storm washer 41-32 Alu-RAL 8004 VE100	41	32	40	100		3079243119	4061245017730
ORKAN storm washer 41-32 alu-RAL 8011	41	32	40	500		3049278119	4061245025100
ORKAN storm washer 41-32 Alu-RAL 8011 VE100	41	32	40	100		3079278119	4061245017709
ORKAN storm washer 41-32 alu-RAL 8012	41	32	40	500		3049240119	4061245025155
ORKAN storm washer 41-32 Alu-RAL 8012 VE100	41	32	40	100		3079240119	4061245017747
ORKAN storm washer 41-32 alu-RAL 9002	41	32	40	500		3049282119	4061245025087
ORKAN storm washer 41-32 Alu-RAL 9002 VE100	41	32	40	100		3079282119	4061245017693
ORKAN storm washer 41-32 alu-RAL 9006	41	32	40	500		3049284119	4061245025070
ORKAN storm washer 41-32 Alu-RAL 9006 VE100	41	32	40	100		3079284119	4061245017686
ORKAN storm washer 41-32 alu-RAL 9007	41	32	40	500		3054132220	4061245024509
ORKAN storm washer 41-32 Alu-RAL 9007 VE100	41	32	40	100		3074132220	4061245017990
ORKAN storm washer 41-32 alu-RAL 9010	41	32	40	500		3049285119	4061245025063
ORKAN storm washer 41-32 Alu-RAL 9010 VE100	41	32	40	100		3079285119	4061245045290
ORKAN storm washer 41-39 mill finish	41	39	40	500		3054139000	4061245018188
ORKAN storm washer 41-39 mill finish VE100	41	39	40	100		3074139000	4061245041124
ORKAN storm washer 41-39 alu-RAL 7016	41	39	40	500		3054139025	4061245024493
ORKAN storm washer 41-39 Alu-RAL 7016 VE100	41	39	40	100		3074139025	4061245017976
ORKAN storm washer 41-39 alu-RAL 7035	41	39	40	500		3054139075	4061245024400
ORKAN storm washer 41-39 Alu-RAL 7035 VE100	41	39	40	100		3074139075	4061245093352
ORKAN storm washer 41-39 alu-RAL 8004	41	39	40	500		3054139043	4061245024462
ORKAN storm washer 41-39 Alu-RAL 8004 VE100	41	39	40	100		3074139043	4061245045306
ORKAN storm washer 41-39 alu-RAL 8012	41	39	40	500		3054139040	4061245024479
ORKAN storm washer 41-39 Alu-RAL 8012 VE100	41	39	40	100		3074139040	4061245017969
ORKAN storm washer 41-39 alu-RAL 9002	41	39	40	500		3054139082	4061245024370





Order description	Width of storm washer [mm]	Inclination angle [°]	Crown width [mm]	PU [pieces]	Price/100 [EUR]	Article number	EAN
ORKAN storm washer 41-39 Alu-RAL 9002 VE100	41	39	40	100		3074139082	4061245017952
ORKAN storm washer 41-39 alu-RAL 9006	41	39	40	500		3054139084	4061245024363
ORKAN storm washer 41-39 Alu-RAL 9006 VE100	41	39	40	100		3074139084	4061245045320
ORKAN storm washer 41-39 alu-RAL 9007	41	39	40	500		3054139220	4061245024318
ORKAN storm washer 41-39 Alu-RAL 9007 VE100	41	39	40	100		3074139220	4061245045337
ORKAN storm washer 55-32 mill finish	55	32	54	400		3049500110	4061245018294
ORKAN storm washer 55-32 mill finish VE100	55	32	54	100		3079500110	4061245045344
ORKAN storm washer 55-32 alu-RAL 7016	55	32	54	400		3049525119	4061245025049
ORKAN storm washer 55-32 Alu-RAL 7016 VE100	55	32	54	100		3079525119	4061245017679
ORKAN storm washer 55-32 alu-RAL 8012	55	32	54	400		3049540119	4061245025001
ORKAN storm washer 55-32 Alu-RAL 8012 VE100	55	32	54	100		3079540119	4061245017662
ORKAN storm washer 55-32 alu-RAL 9002	55	32	54	400		3049582119	4061245024912
ORKAN storm washer 55-32 Alu-RAL 9002 VE100	55	32	54	100		3079582119	4061245017655
ORKAN storm washer 55-32 alu-RAL 9006	55	32	54	400		3049584119	4061245024905
ORKAN storm washer 55-32 Alu-RAL 9006 VE100	55	32	54	100		3079584119	4061245017648
ORKAN storm washer 55-32 alu-RAL 9007	55	32	54	400		3055532220	4061245024035
ORKAN storm washer 55-32 Alu-RAL 9007 VE100	55	32	54	100		3075532220	4061245046600

The RAL colours are similar to RAL

## ORKAN storm washer corrugated

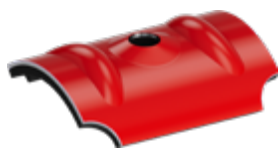

### Cross references

Cross references	Page
Self-drilling screw JF3-Plus-6.8	46
Self-drilling screw JT3-2-6.5	52
Self-drilling screw JT3-6-5.5	54
Self-drilling screw JT3-12-5.5	58
Self-drilling screw JT3-18-5.5	61
Self-tapping screw JZ5-6.3	84

### Application range

- > Crown fixing of corrugated profile sheets
- > Crown fixing of light diffusing panels

### Properties

- > Optimised reinforcement beads
- > Secure waterproofing
- > Aluminium alloy mill finish, coloured (RAL)

### Advantages

- > Increased installation reliability
- > High dimensional stability
- > Optimum load transmission
- > Sophisticated fastening system in combination with self-drilling and self-tapping screws

### Notice

Only use screws with 16mm and 19 mm washer diameter. For determination of the clamp thickness please take the storm washer into account with 3 mm. The guidelines and installation instructions given by the profile and panel manufacturer are to be observed. Storm washers which are not mentioned are special storm washers. Please note surcharges. Storm washers are to be stored in a dry place until installation.

### Applications

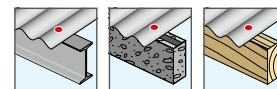

### Technical specifications



### Certifications



### Product in the online shop



Order description	Radius [mm]	for corrugated profile	Length [mm]	PU [pieces]	Price/100 [EUR]	Article number	EAN
ORKAN storm washer W24 mill finish	24	18/76	50	500		3047700110	4061245086101
ORKAN storm washer W24 mill finish VE100	24	18/76	50	100		3077700110	4061245082738
ORKAN storm washer W24 alu- RAL 7016	24	18/76	50	500		3047725119	4061245086118
ORKAN storm washer W24 Alu-RAL 7016 VE100	24	18/76	50	100		3077725119	4061245082776
ORKAN storm washer W24 alu- RAL 9006	24	18/76	50	500		3047784119	4061245086163
ORKAN storm washer W24 Alu-RAL 9006 VE100	24	18/76	50	100		3077784119	4061245082851
ORKAN storm washer W24 alu- RAL 9007	24	18/76	50	500		3050024220	4061245086170
ORKAN storm washer W24 Alu-RAL 9007 VE100	24	18/76	50	100		3070024220	4061245082875
ORKAN storm washer W30 mill finish	30	27/111	50	500		3050030000	4061245084701
ORKAN storm washer W30 mill finish VE100	30	27/111	50	100		3070030000	4061245084763
ORKAN storm washer W30 alu- RAL 7016	30	27/111	50	500		3050030025	4061245084718
ORKAN storm washer W30 Alu-RAL 7016 VE100	30	27/111	50	100		3070030025	4061245084770
ORKAN storm washer W30 alu- RAL 9006	30	27/111	50	500		3050030084	4061245084725
ORKAN storm washer W30 Alu-RAL 9006 VE100	30	27/111	50	100		3070030084	4061245084787
ORKAN storm washer W30 alu- RAL 9007	30	27/111	50	500		3050030220	4061245085739
ORKAN storm washer W30 alu-RAL 9007 VE100	30	27/111	50	100		3070030220	4061245105819
ORKAN storm washer W48 mill finish	48	42/160 + 55/177	50	500		3047400110	4061245082882
ORKAN storm washer W48 mill finish VE100	48	42/160 + 55/177	50	100		3077400110	4061245082905
ORKAN storm washer W48 alu- RAL 7016	48	42/160 + 55/177	50	500		3047425119	4061245082912
ORKAN storm washer W48 Alu-RAL 7016 VE100	48	42/160 + 55/177	50	100		3077425119	4061245082929
ORKAN storm washer W48 alu- RAL 9006	48	42/160 + 55/177	50	500		3047484119	4061245082974
ORKAN storm washer W48 Alu-RAL 9006 VE100	48	42/160 + 55/177	50	100		3077484119	4061245082981

## Selection guide for ORKAN storm washers

Our application engineering will gladly assist you in selecting the right choice of storm washer.

**We only need the following three values:**

- > Top flange width [mm]
- > Profile height [mm]
- > Valley inside width [mm]

Please tell us the three values:

**F +49 2752 908-731 | construction@ejot.com**

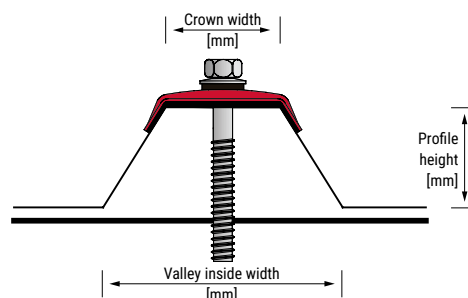

This list is not exhaustive. Profiles which are not listed or marked with asterisk \* are available upon request.

Manufacturer	Profile description	Storm washer profile
Alubel	alubel 28	41 – 32
	alubel 21	26 – 34
	alubel 40	41 – 32
	alubel 44	31 – 31
	Alutech Dach	26 – 27
Aluform	Aluform 20/125	41 – 32
	Aluform 29/124	20 – 34
	Aluform 30/153	26 – 34
	Aluform 40/167	35 – 23*
	Aluform 42/250	31 – 31
	Aluform 45/150	26 – 27
	Aluform 45/200	41 – 24*
	Alutherm DT 900	26 – 27
	Alutherm DT 1000	31 – 31
	Corrugated sheet 18/76	W 24
	Corrugated sheet 35/137	W 43
	Corrugated sheet 55/177	W 48
	Arcelor	A 35/207
AL 34/207		41 – 39
B 35/207		41 – 16
39/333 T		26 – 27
AL 40/183		41 – 16
A 40/183		41 – 24*
44/180		53 – 36
AL 45/150		26 – 27
50/262.5		46 – 43
85/280		41 – 39
100/275		41 – 24*
105/345		41 – 24*
106/250		41 – 16
Ondatherm 1001 TS		26 – 27
Ondafibre 3005 T		26 – 27
Agratherm 1001 TS	26 – 27	
Corrugated sheet 18/76	W24	
Balex	Balextherm-PV-R	26 – 27

Manufacturer	Profile description	Storm washer profile
Bieber	20/125	41 – 32
	30/262K	41 – 50
	35/207	41 – 32
	40/183/183 S	41 – 16
	50/250	41 – 39
	50/262	46 – 43*
	58/315K	53 – 36*
	70/200	53 – 18*
	80/307	41 – 32
	89/305	41 – 32
	100/275	41 – 24*
	106/250	41 – 16
	110/333	41 – 16
Brucha	135/310	41 – 24*
	150/280	41 – 24*
	160/250	41 – 16
	170/250	41 – 16
	DP72/82/102/122/142/162/182/202	26 – 15
	DP-F	26 – 15
	DS 20/115	26 – 34
	DS 35/190	41 – 39
	DS 35/206	36 – 40
	DS Sinus 35/143	W 30
DS Staalprofil	SISCOROOF 4G	21 – 16
	SISCOTEC ROOF 4G	21 – 16
	FALK 1100 TR 3+	53 – 36
	FALK 1000/35 TR	53 – 36
Falk	FALK 1000 TR	53 – 36
	EL 22/214	36 – 40
	EL 30/220	41 – 50
	EL 35/207	41 – 32
Feilmeier	EL 39/333/S	36 – 32*
	EL 40/183	41 – 16
	EL 45/333/S	31 – 37
	EL 50/250	53 – 36*





## Selection guide for ORKAN storm washers

This list is not exhaustive. Profiles which are not listed or marked with asterisk \* are available upon request.

Manufacturer	Profile description	Storm washer profile	Manufacturer	Profile description	Storm washer profile	
Feilmeyer	Corrugated sheet EL 18/76	W24		JI 40.183.915	41 – 16	
	Dakprofil 18 - 76	W 24		JI 50.250.1000	55 – 32	
	Dakprofil 42 - 960	W 48		Joriside	JI 56.317.945	53 – 42*
Dakprofil 35 - 1000	41 – 24*	JI Roof 1000	26 – 27			
Finish Profiles	Dakprofil 40 - 915	41 – 16	JI Ecopaneel 1000	23 – 33		
	Dakprofil 50 - 1000	55 – 32	Kingspan	KS 1000 RW	32 – 25	
	Dakprofil 58 - 945 KD	53 – 36*		KS 1000 FF	23 – 33	
	Dakprofil 70R - 800	53 – 18*	Klinger & Partner	35.207.1035	41 – 39	
	35/207	41 – 32		39.333.1000	26 – 34	
	40/183	41 – 16	Klöckner	KAS AL-20/125 A	41 – 32	
	50/250	55 – 32		KAS AL-30/153 A	26 – 27	
	85/280	41 – 32		KAS-35/207	41 – 32	
	100/275	41 – 24*		KAS AL-40/167 A	35 – 23*	
	135/310	41 – 24*		KAS-40/183	41 – 16	
	Fischer	150/280		41 – 24*	KAS AL-45/200 A	41 – 24*
		165/250		41 – 16	KAS-50/250	55 – 32
		Sinus 18		W 24	KAS-85/280	41 – 39
	Sinus 27	W 30		KAS-89/305	41 – 32	
	Sinus 42	W 48		KAS -18/76	W 24	
	DL 70; 80; 100; 120; 140; 160	41 – 32	KAS -42/160	W 48		
	20/220	41 – 50	KAS -55/177	W 48		
	W-20/990	26 – 34	KAS -D 65 - 115	36 – 40		
	W-20/1100	26 – 50	KAS -D 68	21 – 16		
Friedrich von Lien AG	W-35/1035	41 – 39	KAS -D 80	41 – 32		
	W-45R/900	41 – 24*	KAS -D 62 - 142	26 – 15		
	W-45ER/1000	26 – 34	Lattonedil	Isocopre	21 – 25	
W-155/840	41 – 24*	Eurocinque		21 – 25		
Weckmann	W-1/1064	W 24	Eurocopre	21 – 25		
	Hoesch Thermorock Dach	23 – 33	35 – 207	41- 32		
	Hoesch Isodach RD	32 – 25	22 – 214	41 – 39		
Hoesch Bausy- steme	T 35.1	41 – 39	20 – 75	26 – 34		
	T 40.1	41 – 16	45-333 S	26 – 27		
	T 50.1	55 – 32	Laukien	40 – 100	31 – 31	
	T 85.1	41 – 32		50 – 250	41 – 39	
	T 100.1	41 – 24*	18 / 76	W 24		
	T 106.1	41 – 16	27 / 111	W 30		
	WP 18/76	W 24	42 / 160	W 48		
	WP 42/160	W 48	55 / 177	W 48		
	WP 27/111	W 30	Lindab	LP 20	26 – 34	
	Italpanelli	Penta		21 – 25	LP 35	41 – 32
JI 33.250.1000		23 – 33		LP 1100	26 – 45*	
Joriside	JI 45.333.1000	26 – 27	Sinus 18	W 24		
	JI Vulcasteel Roof	26 – 34	Luxmetall	LM40 250 1000	26 – 27	
	JI 35.207.1035	41 – 39		LM19 156 1094	26 – 45*	





## Selection guide for ORKAN storm washers

This list is not exhaustive. Profiles which are not listed or marked with asterisk \* are available upon request.

Manufacturer	Profile description	Storm washer profile	Manufacturer	Profile description	Storm washer profile
Luxmetall	LM 27-111-1000	W 30	Münker	M 150/280	41 – 24*
	20-75	26 – 34		M 160/250	41 – 16
	22-214	41 – 39		M 18/76; M 18.1/76	W 24
	35-207	41 – 32		M 27/111; M 27.1/111	W 30
	40-100	31 – 31		20.125/8	41 – 32
	45-150	26 – 27		20.136/8	31 – 45*
Maas	45-333 S	26 – 27	25.280/3	41 – 16	
	50-250	41 – 39	25.268/4	26 – 38*	
	Corrugated sheet 18-76	W24	30.207/5	35 – 23*	
	Corrugated sheet 27-111	W30	30.153/7	26 – 34	
Metecno	Corrugated sheet 55-177	W48	35.207/5	41 – 39	
	Isopaneel	26 – 27	40.183/5	41 – 16	
	G4	21 – 16	40.250/4	26 – 27	
	Hipertec Dach	21 – 16	45.150/6	26 – 27	
	Hipertec Dach Sound	21 – 16	45.333/3	26 – 27	
	Toproof DG	20 – 34	50.250/4	55 – 32	
	SISCO	21 – 16	50.262,5/4	46 – 43*	
	SP 20	26 – 34	Corrugated sheet 18.76	W 24	
	SP 26	41 – 24*	Corrugated sheet 55.177	W48	
	SP 30	41 – 50	Corrugated sheet 27.111	W30	
Montana	SP 35	41 – 32	Plannja	Plannja 19	26 – 45*
	SP 40	41 – 16		Plannja 20-105	26 – 38*
	SP 44	31 – 22*		Plannja 35	41 – 32
	SP 45	41 – 32		Sinus 18	W24
	SP 59	35 – 23*		Sinus 51	W48
	SP 80	41 – 16		Plannja 20	36 – 40
	MTD TL 65	35 – 23*		Plannja 60	41 – 16
	MTD TL 85	35 – 23*		Plannja 30	31 – 37
	MTD TL 105	35 – 23*		Plannja 45	41 – 39
	MTD TL 125	35 – 23*		T18 DR	35-47
	MTD TL 145	35 – 23*		T20 M	35-47
	SP 18/1064	W 24		T35 DR	41-32
	SP 27/1000	W 30		T35 M	41-32
	SP 42/960	W 48		T35 E	41-32
M-Profile	KP	36 – 40	Polmetal	T40	41-39
	M 20/210; M 20KD/210	41 – 39		T45P	32-25
	M 35/207	41 – 39		T50P	46-43
	M 35.1/207	35 – 47		20/154	26 – 34*
	M 40/183	41 – 16		26/143	41 – 32
	M 40.1/183	41 – 24*		30/207	35 – 47
Münker	M 40/333; M 40KD/333	26 – 27	Proge	30/220	41 – 50
	M 50/250	55 – 32		30 KD	41 – 50
	M 85/280	41 – 32		35/207	41 – 39
	M 100/275	41 – 24*		40/183	41 – 16





## Selection guide for ORKAN storm washers

This list is not exhaustive. Profiles which are not listed or marked with asterisk \* are available upon request.

Manufacturer	Profile description	Storm washer profile	Manufacturer	Profile description	Storm washer profile
Proge	45/150	41 – 32	Salzgitter	PS 100/275	41 – 24*
	45/333	32 – 25		SIP D	41 – 32
	50/250	55 – 32	Siegmetall	S 18/76	W 24
	58 KD	53 – 42*		S 35/207	35 – 47
	59/225	35 – 23*		40/183	41 – 16
	70/200	53 – 18*		40/333	26 – 27
	80/277	41 – 16		50/250	55 – 32
	85/280	41 – 39		CB 75/305	41 – 39
	89/305	41 – 32		85/280	41 – 32
	100/275	41 – 24*	100/275	41 – 16	
	105/345	41 – 24*	Trimo	SNV	26 – 27
	106/250	41 – 16		WU 20/125	41 – 32
	Corrugated sheet 18/76	W 24	WU 30/200	20 – 34	
	Corrugated sheet 27/111	W 30	WU 30D/207	35 – 47	
	Corrugated sheet 42/160	W 48	WU 30W/207	35 – 47	
Corrugated sheet 55/177	W 48	WU 35/207	41 – 32		
Romakowski	D62; D82; D102; D122; D142; D162; D182	26 – 15	Wurzer Profiliertechnik	WU 40/183	41 – 16
	19(KD)/1050	26 – 50		WU 45/333	26 – 27
35R/1035	41 – 32	WU 50/250		55 – 32	
40R/915	41 – 16	WU 80/307		41 – 32	
50R/1000	55 – 32	WU 100/275		41 – 24*	
70R/800	53 – 18*	WU 18/76		W 24	
85R/1120	41 – 39	WU 27/111		W 30	
89R/915	41 – 32	WU 55/177		W 48	
100R/825	41 – 24*				
30KD/1050	41 – 50				
Sab	45KD/1000	32 – 25			
	45KD/1000S	26 – 27			
	58KD/945	53 – 36*			
	65-75-95-115-135	36 – 40			
	D 70.1000 TL	31 – 37			
	D 90.1000 TL	31 – 37			
	D 110.1000 TL	31 – 37			
	D 130.1000 TL	31 – 37			
	D 135.1000 TL	36 – 40			
	D 160.1000 TL	31 – 37			
	18 / 988	W 24			
	42 / 960	W 48			
	27 / 1000	W 24			
	Salzgitter	PS 35/207	41 – 32		
		PS 40/183	41 – 16		
PS 50/250		55 – 32			
PS 85/280		41 – 39			

# ECORIV® rivets

Open, closed or high-strength versions, multigrip or folding blind rivets, with flat, countersunk or large head and many more - there are virtually no limits to the range of available dimensions, types and versions.

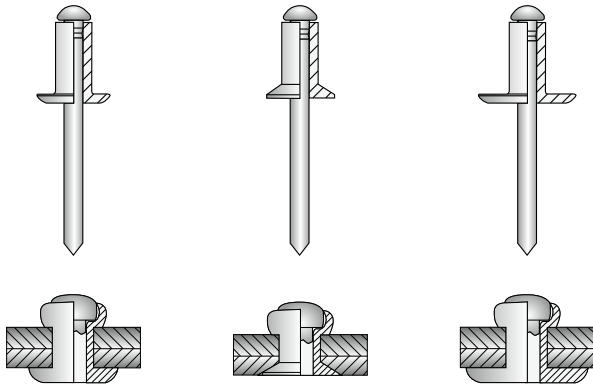

## Standard blind rivet

Standard blind rivets are available with flat, countersunk or large head. The product range includes the versions and special types described in the DIN EN ISO 15977 to 15984 as well as 16582 and 16584. Special types are rivets with a functional principle according to the above-mentioned norms, but with deviations concerning certain dimensions, functional properties or material combinations.

## Closed-end rivets

Due to their cup-shaped rivet body, closed-end rivets are the experts for rainproof processing. Thanks to this special design, the remaining rivet mandrel is captive as well. Furthermore, the rivet forms an even, burr-free closing head and is thus particularly suitable for automated processing. Because of the mentioned features, the closed-end rivet is a preferred fastening element in the building industry.

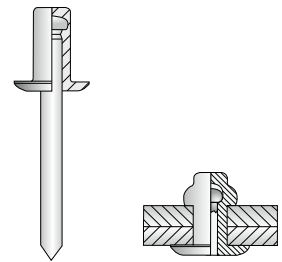

## Multigrip rivets

The multigrip rivet can be clearly distinguished from a standard blind rivet by its specially stamped rivet shank. Its constructive design guarantees a number of outstanding functional properties.

Nowadays, multigrip rivets are used in virtually every branch of industry, for example in the vehicle construction, air-conditioning technology or container and apparatus construction. Furthermore, the multigrip rivet is perfectly suitable as a repair rivet.

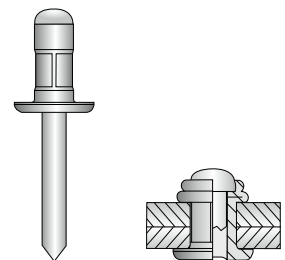

## Folding blind rivets

The large-scale folding of the closing head of folding blind rivets ensures a uniform distribution of the occurring forces, as a result of which especially soft or brittle components are less heavily loaded.

Folding blind rivets are used in all areas of industrial lightweight construction. Additionally, the joint is splash-water-protected thanks to the locking of the remaining rivet mandrel. The EJOT ECORIV® folding blind rivet features an assembled neoprene sealing ring.

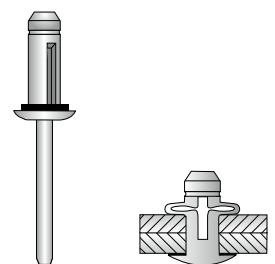

# Operating principle (example: blind rivet)

## Form-fitted riveted joint of several components

The two-part blind rivet consists of a rivet body which is mounted to a rivet mandrel. Only one side of the components which are to be connected must be accessible for processing. The blind rivet is installed by pulling back the mandrel with a special tool, whereupon the mandrel head penetrates into the rivet and expands the protruding material to a closing head.

### The rivet body is the element which creates the joint.

It is formed by the rivet mandrel and remains in the component non-detachably. The body geometry is selected based on

- > the expected mechanical loadings,
- > the corrosion requirements,
- > the design of the components,
- > the thermal stress and to some extent also
- > the optics (flat or countersunk head).

### The rivet mandrel is necessary to form the rivet body.

It is designed according to the body type and the requirements concerning the processing and functional properties. For some special rivet types, the rivet mandrel remaining in the joint after the installation is used to increase the shear force of the rivet.

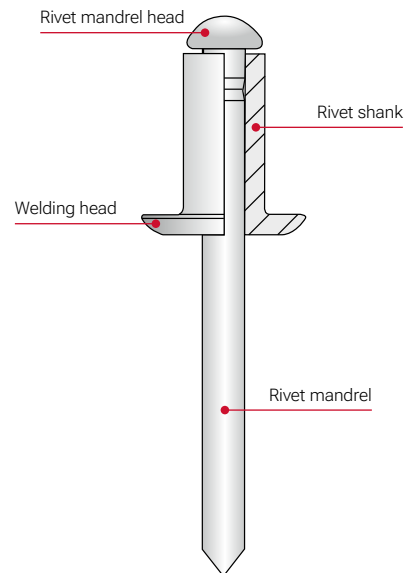
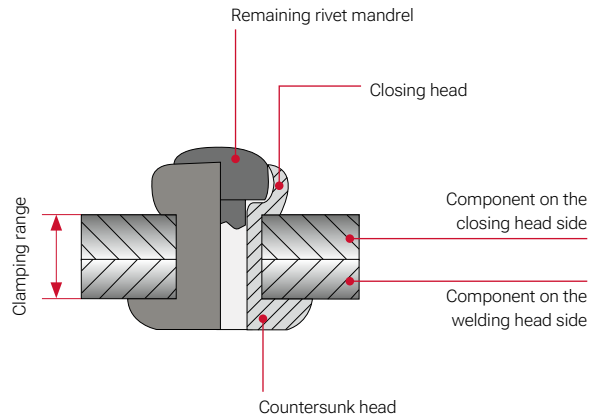

### Rivet body

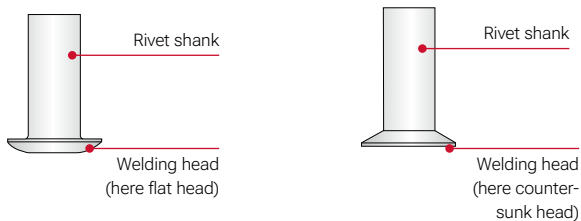

### Rivet mandrel

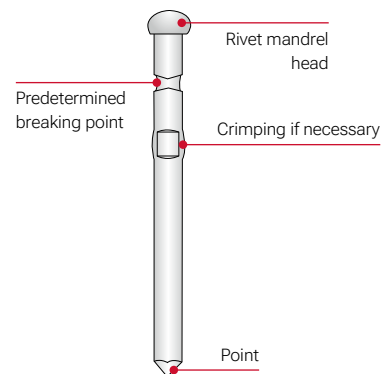

# Correct installation of rivets

Special tools are necessary to install blind rivets. The choice of tool depends on the type of rivet (Bulbtite nose piece, retaining or facade nose piece) and the amount of processing (hand riveter, lever riveter or battery riveter).

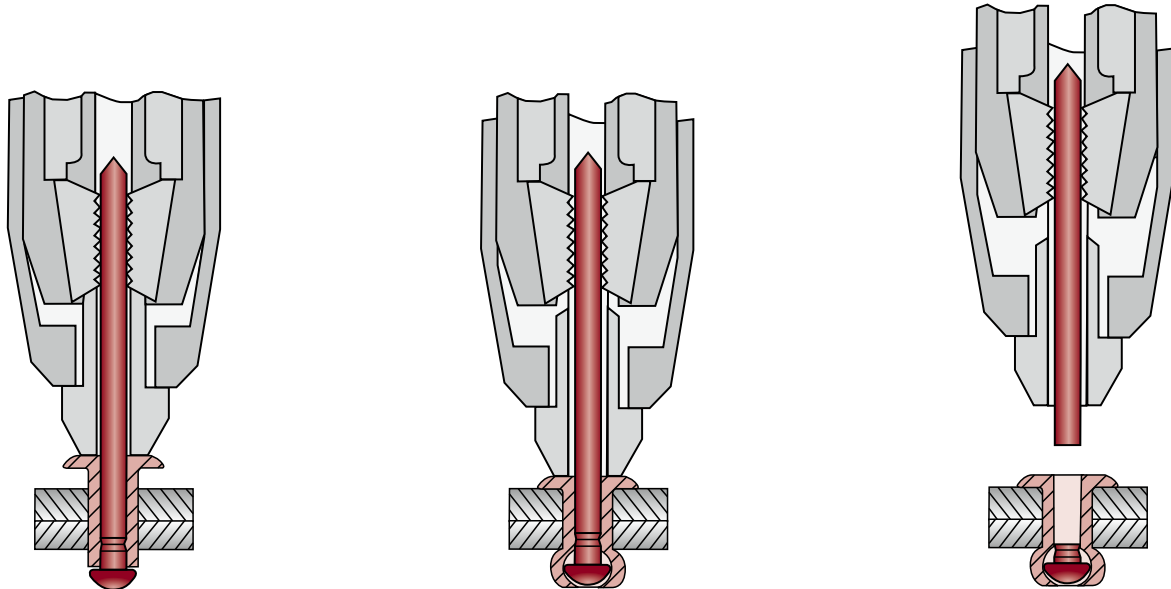

## The Assembly instructions (example: battery riveter)

The mandrel of the blind rivet is set into the installation tool and then inserted into the rivet hole. The rivet mandrel is gripped and pulled with the clamping jaws by triggering the installation tool stroke. The rivet mandrel head thus deforms the shaft end of the rivet body.

The process is completed when the mandrel head reaches the height of the component surface. This position is connected with a strong force increase, at which the rivet mandrel tears off at its predetermined breaking point. The torn mandrel is removed, the residual rivet mandrel remains in the rivet.



Rivet mandrel and clamping jaws

## Determining the drill hole diameter

### Product overview

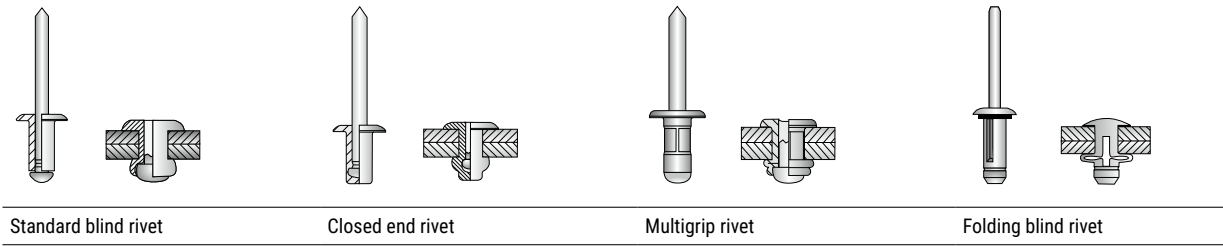

#### Standard blind rivet

Type [mm]	d <sub>0</sub> [mm]
5.0xL*	5.1

\*see chapter Rainscreen Facade

#### Closed end rivet

Type [mm]	d <sub>0</sub> [mm]
4.8xL	4.9

#### Multigrip rivet

Type [mm]	d <sub>0</sub> [mm]
4.0xL	4.1
4.8xL	4.9

#### Folding blind rivet

Type [mm]	d <sub>0</sub> [mm]
5.2xL	5.3

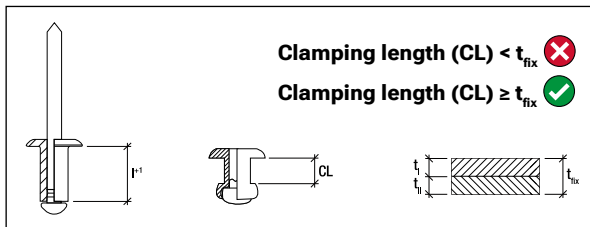

## Closed-end rivet ECORIV® aluminium/stainless steel



Cross references	Page
Cordless riveter ECORIV	138
Drill HSS	139

### Application range

- > For side lap stitching of profiled sheets

### Characteristics

- > Rivet body made of aluminium (Al)
- > Mandrel made of stainless steel (E)
- > Captive locked
- > Flat head, closed
- > ETA-22/0641

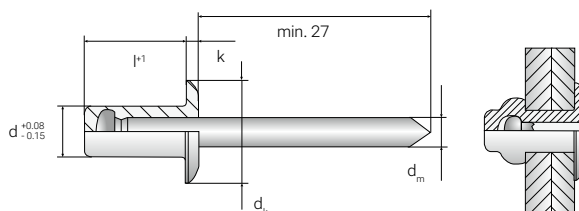

### Applications

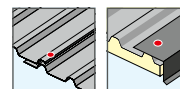

### Technical specifications

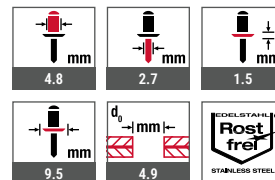

### Certifications



### Assembly instructions



### Product in the online shop



Order description	l¹ [mm]	Clamping thickness [mm]	PU [pieces]	Price/100 [EUR]	Article number	EAN
BBN ECORIV AL/E 4.8x8.0	8.0	0.5 – 3.5	500		9334403000	4061245021690
BBN ECORIV AL/E 4.8x9.5	9.5	3.0 – 5.0	500		9334404000	4061245109152
BBN ECORIV AL/E 4.8x12.5	12.5	6.0 – 8.0	500		9334405000	4061245109169
BBN ECORIV AL/E 4.8x14.0	14.0	7.5 – 9.5	500		9334406000	4061245021720
BBN ECORIV AL/E 4.8x16.0	16.0	9.0 – 11.0	500		9334408000	4061245105734
BBN ECORIV AL/E 4.8x21.0	21.0	12.5 – 16.0	500		9334411000	4061245109176

## Multigrip rivet ECORIV® aluminium/stainless steel



Cross references	Page
Cordless riveter ECORIV	138
Drill HSS	139

## Application range

- > For side lap stitching of profiled sheets

## Properties

- > Rivet body made of aluminium (Al)
- > Mandrel made of stainless steel (E)
- > Captive locked
- > Flat head, open
- > ETA-22/0641\*

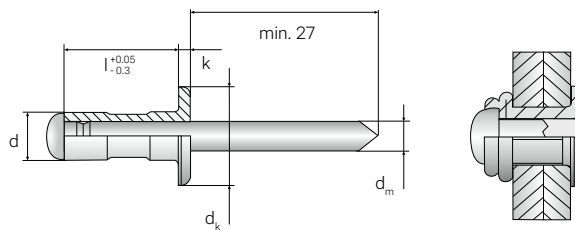

## Applications



## Technical specifications



## Certifications



## Assembly instructions



Order description	d [mm]	l* [mm]	dk [mm]	dm [mm]	k [mm]	Drill hole diameter [mm]	Clamping thickness [mm]
MBN ECORIV AL/E 4.0x9.5*	4.0	9.5	7.9	2.3	1.2	4.1	1.2 – 6.3
MBN ECORIV AL/E 4.0x9.5 RAL 7016*	4.0	9.5	7.9	2.3	1.2	4.1	1.2 – 6.3
MBN ECORIV AL/E 4.0x9.5 RAL 9002*	4.0	9.5	7.9	2.3	1.2	4.1	1.2 – 6.3
MBN ECORIV AL/E 4.0x9.5 RAL 9006*	4.0	9.5	7.9	2.3	1.2	4.1	1.2 – 6.3
MBN ECORIV AL/E 4.0x9.5 RAL 9007*	4.0	9.5	7.9	2.3	1.2	4.1	1.2 – 6.3
MBN ECORIV AL/E 4.8x10.3	4.8	10.3	9.8	2.8	1.5	4.9	1.6 – 6.3
MBN ECORIV AL/E 4.8x10.3 RAL 7016	4.8	10.3	9.8	2.8	1.5	4.9	1.6 – 6.3
MBN ECORIV AL/E 4.8x10.3 RAL 9002	4.8	10.3	9.8	2.8	1.5	4.9	1.6 – 6.3
MBN ECORIV AL/E 4.8x10.3 RAL 9006	4.8	10.3	9.8	2.8	1.5	4.9	1.6 – 6.3
MBN ECORIV AL/E 4.8x10.3 RAL 9007	4.8	10.3	9.8	2.8	1.5	4.9	1.6 – 6.3
MBN ECORIV AL/E 4.8x15.1	4.8	15.1	9.8	2.8	1.5	4.9	4.8 – 11.1
MBN ECORIV AL/E 4.8x15.1 RAL 7016	4.8	15.1	9.8	2.8	1.5	4.9	4.8 – 11.1
MBN ECORIV AL/E 4.8x15.1 RAL 9002	4.8	15.1	9.8	2.8	1.5	4.9	4.8 – 11.1
MBN ECORIV AL/E 4.8x15.1 RAL 9006	4.8	15.1	9.8	2.8	1.5	4.9	4.8 – 11.1
MBN ECORIV AL/E 4.8x15.1 RAL 9007	4.8	15.1	9.8	2.8	1.5	4.9	4.8 – 11.1
MBN ECORIV AL/E 4.8x24.8	4.8	24.8	9.8	2.8	1.5	4.9	12.7 – 19.8





**Product in the online shop**



Order description	PU [pieces]	Price/100 [EUR]	Article number	EAN
MBN ECORIV AL/E 4.0x9.5*	500		9337360000	4061245021379
MBN ECORIV AL/E 4.0x9.5 RAL 7016*	100		9337360025	4061245046679
MBN ECORIV AL/E 4.0x9.5 RAL 9002*	100		9337360082	4061245046686
MBN ECORIV AL/E 4.0x9.5 RAL 9006*	100		9337360084	4061245046693
MBN ECORIV AL/E 4.0x9.5 RAL 9007*	100		9337360220	4061245046709
MBN ECORIV AL/E 4.8x10.3	500		9337361000	4061245021386
MBN ECORIV AL/E 4.8x10.3 RAL 7016	100		9337361025	4061245046716
MBN ECORIV AL/E 4.8x10.3 RAL 9002	100		9337361082	4061245046723
MBN ECORIV AL/E 4.8x10.3 RAL 9006	100		9337361084	4061245046730
MBN ECORIV AL/E 4.8x10.3 RAL 9007	100		9337361220	4061245046747
MBN ECORIV AL/E 4.8x15.1	500		9337362000	4061245021393
MBN ECORIV AL/E 4.8x15.1 RAL 7016	100		9337362025	4061245046754
MBN ECORIV AL/E 4.8x15.1 RAL 9002	100		9337362082	4061245046761
MBN ECORIV AL/E 4.8x15.1 RAL 9006	100		9337362084	4061245046778
MBN ECORIV AL/E 4.8x15.1 RAL 9007	100		9337362220	4061245046785
MBN ECORIV AL/E 4.8x24.8	500		9337363000	4061245021607

**\*Not part of the ETA**

Further versions  
available



Blind rivet ECORIV®  
aluminium/stainless  
steel

## Folding blind rivet ECORIV® aluminium/aluminium



Cross references	Page
Cordless riveter ECORIV	138
Drill HSS	139

### Application range

- > For side lap stitching of profiled metal and plastic sheets
- > For fixing standing seam systems (clips) on metal substructures
- > For fixing standing seam systems (clips) on milled system rails

### Properties

- > Rivet body made of aluminium (Al)
- > Mandrel made of aluminium (Al)
- > Captive locked
- > Flat head, open
- > With neoprene sealing ring
- > ETA-22/0641

### Applications

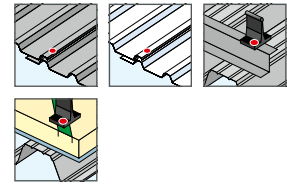

### Technical specifications

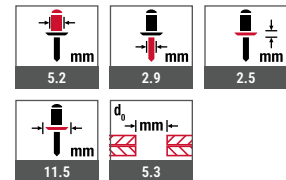

### Certifications

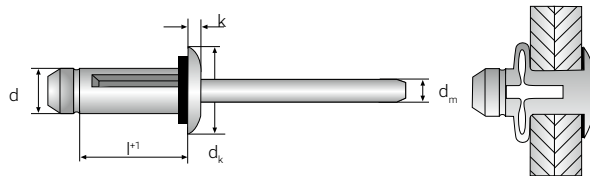

### Assembly instructions



### Product in the online shop



Order description	l¹ [mm]	Clamping thickness [mm]	PU [pieces]	Price/100 [EUR]	Article number	EAN
PBN ECORIV ALU 5.2x17.5	17.5	1.3 – 4.7	500		9385641000	4061245021751
PBN ECORIV ALU 5.2x20.5	20.5	3.0 – 7.7	500		9385642000	4061245021768
PBN ECORIV ALU 5.2x22.2	22.2	4.8 – 9.5	500		9385643000	4061245021775
PBN ECORIV ALU 5.2x25.4	25.4	8.0 – 12.7	500		9385644000	4061245021782
PBN ECORIV ALU 5.2x28.6	28.6	11.1 – 16.9	500		9385645000	4061245021799
PBN ECORIV ALU 5.2x31.8	31.8	14.3 – 19.1	250		9385646000	4061245021805

# Metal construction fasteners

Tensile- and pressure-resistant connections for industrial lightweight construction

## Characteristics

- > Universal metal construction anchor and GU threaded sleeve made of stainless steel
- > Ring bolt forged steel, zinc-plated and stainless steel
- > For use in steel substructure (type JZ 5 ...  $\varnothing$  6.3 mm)
- > For use in timber substructure (type JA3 ...  $\varnothing$  6.5 mm)
- > Repeat use of GU-threaded sleeve possible

## Notice

EJOT metal construction anchors may only be loaded in axial direction of the screw. The load-bearing capacity and dimensions of the structure and substructure must be sufficient.

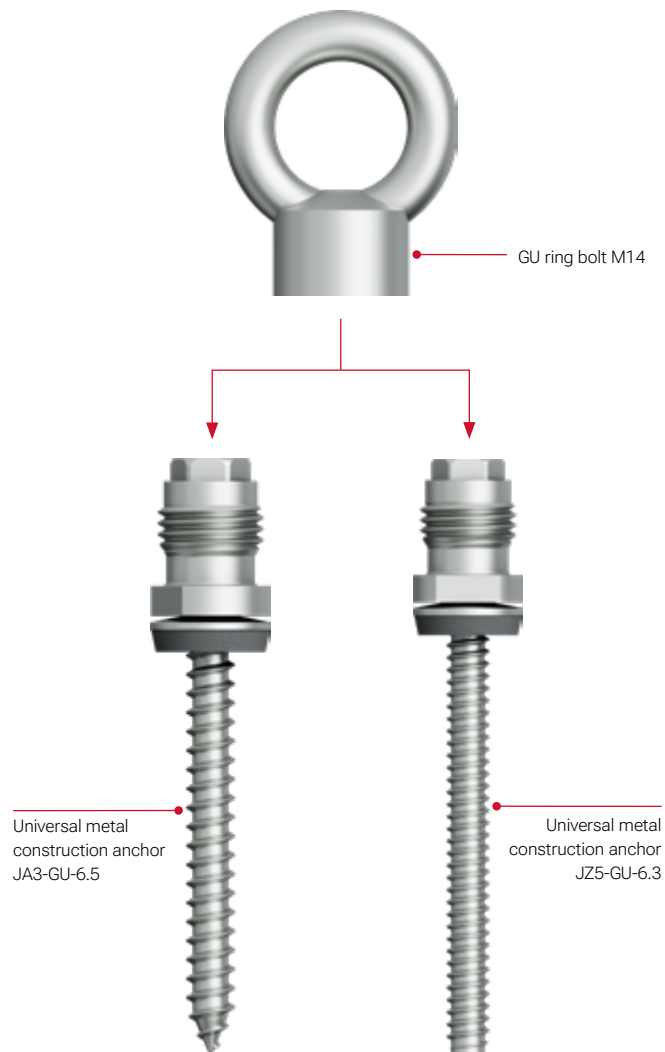

## Universal metal construction anchor JA3-GU-6.5



Cross references	Page
GU Ring bolt	117
GU threaded sleeve	117
Cordless screwdriver	
ASCM QSW	135
Drill HSS	139
Socket wrench insert SW3/8"	141

### Application range

- > For installation into timber

### Characteristics

- > A2 stainless steel
- > Consisting of GU threaded sleeve and JA3 self-tapping screw

### Notice

EJOT metal construction anchors may only be loaded in axial direction of the screw. The load-bearing capacity and dimensions of the structure and substructure must be sufficient.

### Technical specifications

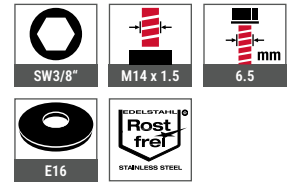

### Characteristic values for the load-carrying capacity Timber substructure

Installation depth [mm]	30	50	60	75
Drill hole diameter [mm]	4.5	4.5	4.5	4.5
$N_{R,k}^*$ [kN]	1.5	2.5	3.0	3.7

\*Based on the approval of the screws ETA-10/0200 The tensile forces that can be absorbed by the attachment part (ring bolt) must be observed.

### Product in the online shop



Order description	Effective length [mm]	Length [mm]	PU [pieces]	Price/100 [EUR]	Article number	EAN
JA3-GU-6.5x55 E16	55	75	50		9403611311	4061245013213
JA3-GU-6.5x70 E16	70	90	50		9403911311	4061245013206
JA3-GU-6.5x80 E16	80	100	50		9404011311	4061245013190
JA3-GU-6.5x95 E16	95	115	50		9404111311	4061245013183
JA3-GU-6.5x105 E16	105	125	50		9404211311	4061245013176
JA3-GU-6.5x130 E16	130	150	50		9404411311	4061245013169
JA3-GU-6.5x155 E16	155	175	50		9404611311	4061245105543
JA3-GU-6.5x180 E16	180	200	50		9404711311	4061245013145

## Universal metal construction anchor JZ5-GU-6.3



### Application range

- > For installation into steel  $\geq 2$  mm
- > For installation into aluminium  $\geq 3$  mm

### Characteristics

- > A2 stainless steel
- > Consisting of GU threaded sleeve and JZ5-6.3xL self-tapping screw

### Notice

EJOT metal construction anchors may only be loaded in axial direction of the screw. The load-bearing capacity and dimensions of the structure and substructure must be sufficient.

### Technical specifications

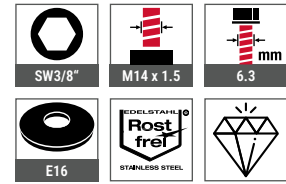

Cross references	Page
Drill hole chart	83
GU Ring bolt	117
GU threaded sleeve	117
Cordless screwdriver	
ASCM QSW	135
Drill HSS	139
Socket wrench insert SW3/8"	141

### Characteristic values for the load-carrying capacity Steel substructure S235 J(xx) (St 37)

Thickness of substructure [mm]	2.0	3.0	4.0	5.0	6.0	$\geq 7.0$
Drill hole diameter [mm]	5.3	5.3	5.3	5.5	5.5	5.7
$N_{R,k}^*$ [kN]	3.6	6.0	8.8	11.6	13.4	13.4

\*Based on the approval of the screws ETA-10/0200 The tensile forces that can be absorbed by the attachment part (ring bolt) must be observed.

### Product in the online shop



Order description	Clamping thickness [mm]	Screw length L [mm]	PU [pieces]	Price/100 [EUR]	Article number	EAN
JZ5-GU-6.3x13 E16	13	40	50		9491311311	4061245081755
JZ5-GU-6.3x25 E16	25	53	50		9491411311	4061245081762
JZ5-GU-6.3x35 E16	35	63	50		9491511311	4061245081779
JZ5-GU-6.3x55 E16	55	83	50		9491611311	4061245081786
JZ5-GU-6.3x65 E16	65	93	50		9491711311	4061245081793
JZ5-GU-6.3x75 E16	75	103	50		9491811311	4061245081809
JZ5-GU-6.3x85 E16	85	113	50		9491911311	4061245081816
JZ5-GU-6.3x95 E16	95	123	50		9492011311	4061245081823
JZ5-GU-6.3x105 E16	105	133	50		9492111311	4061245081830
JZ5-GU-6.3x115 E16	115	143	50		9492211311	4061245081847
JZ5-GU-6.3x125 E16	125	153	50		9492311311	4061245081854
JZ5-GU-6.3x135 E16	135	163	50		9492411311	4061245081878
JZ5-GU-6.3x155 E16	155	183	50		9492511311	4061245083308
JZ5-GU-6.3x175 E16	175	203	50		9492611311	4061245081885
JZ5-GU-6.3x195 E16	195	223	50		9492711311	4061245081892
JZ5-GU-6.3x215 E16	215	243	50		9492811311	4061245081908

## GU ring bolt M14



### Application range

- > For Universal metal construction anchor GU

### Characteristics

- > Zinc-plated forged steel
- > Axial load capacity: 490 kg

### Technical specifications



Cross references	Page
Metal construction anchor JA3-GU-6.5	115
Metal construction anchor JZ5-GU-6.3	116
GU threaded sleeve	117

### Product in the online shop



Order description	Rind diameter [mm]	PU [pieces]	Price/100 [EUR]	Article number	EAN
GU Ring bolt M14x1.5 steel, zink plated	25.0	50		9409400501	4061245013138

## GU threaded sleeve



### Application range

- > Can be extended to a universal metal construction anchor GU
- > Can be combined with all EJOT JA3 self-tapping screws with diameter 6.5 mm
- > Can be combined with all EJOT JA5 self-tapping screws with diameter 6.3 mm
- > For ring bolts M14

### Characteristics

- > A2 stainless steel
- > Repeat use of GU-threaded sleeve possible

### Notice

Effective length of universal metal construction anchor GU + 20 mm = length of required screw

### Technical specifications



Cross references	Page
Metal construction anchor JA3-GU-6.5	115
Metal construction anchor JZ5-GU-6.3	116
GU ring bolt	117

### Product in the online shop



Order description	Length [mm]	PU [pieces]	Price/100 [EUR]	Article number	EAN
GU threaded sleeve	18	50		9400100300	4061245013336

# DEKTITE® Pipe Flashings

Perfect seal for pipes on roofs and facades.

Due to the flexible rubber pleats, thermal changes in length of the pipes or sheathing elements are not obstructed. Fatigue fractures, which might for example occur with rigid pipe feedthroughs, can be prevented with DEKTITE® flashings.

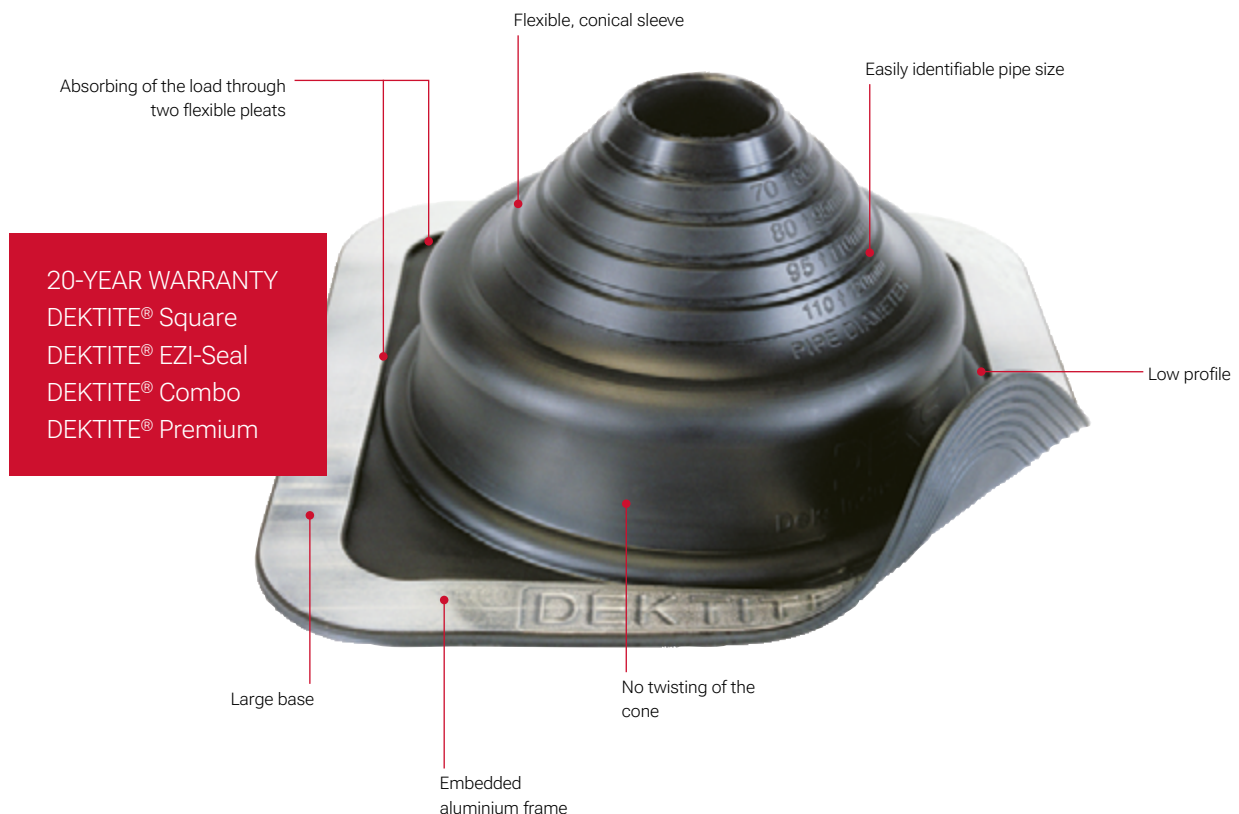

## Properties

- > Standard dimensions for pipe diameters of up to 760 mm
- > Weather-resistant due to building industry-approved EPDM
- > Unsusceptible to UV-radiation
- > Adaptable to all roof profiles

## Notice

When using the DEKTITE® pipe flashing please note the specifications stated in DIN 1090-4, B11 "Öffnungen in Dächern" have to be considered.

Pipe flashings may not be installed in cross or side laps.

## Advantages

- > Long service life
- > Temperature resistance EPDM (black or grey) permanent 50 °C to +115 °C, short-term up to +150 °C
- > Temperature resistance silikone (red) permanent 50 °C to +200 °C, short-term up to +250 °C
- > Flexible adjustment
  - to various profiles
  - to all pipe materials
  - to pipe diameters up to 760 mm

## DEKTITE® Square Set



Cross references	Page
Joint sealant	124
Tightener	124
Hose clamp	125

### Application range

- > For waterproofing pipes on trapezoidal or sinusoidal metal roofs or corrugated fibre cement roofs

### Properties

- > Version EPDM (black)
- > Temperature resistance EPDM (black or grey) permanent 50 °C to +115 °C, short-term up to +150 °C
- > Temperature resistance silicone (red) permanent 50 °C to +200 °C, short-term up to +250 °C

### Advantages

- > Perfect seal on roof and facade
- > No interference of thermal elongation of pipes
- > No fatigue fractures
- > 20-year warranty on material

### Notice

Use folding blind rivets for fibre cement boards. Profile height max. 45 mm.

### Included in delivery

- 1 pipe flashing
- 1 cartridge of EJOPLAST joint sealant
- 1 self-drilling screw set - optionally folding blind rivet set

### Assembly instruction



### Product in the online shop



Order description	For pipe diameter [mm]	Base [mm]	Roof pitch [°]	Content Cartridge [ml]	Content Screws [pieces]	PU [set]	Price/1 [EUR]	Article number	EAN
DFE 100 B Set	0 – 35	100 x 100	0 – 60	80	8	1		8200004704	4061245013954
DFE 101 B Set	5 – 55	139 x 139	0 – 35	80	8	1		8200104704	4061245013800
DFE 103 B Set	5 – 127	221 x 221	0 – 35	80	16	1		8200304704	4061245013787
DFE 104 B Set	75 – 175	280 x 280	0 – 35	80	20	1		8200404704	4061245013763
DFE 106 B Set	125 – 230	363 x 363	0 – 35	80	28	1		8200604704	4061245013749
DFE 107 B Set	150 – 300	456 x 456	0 – 35	310	32	1		8200704704	4061245013725
DFE 109 B Set	230 – 508	681 x 681	0 – 35	310	40	1		8200904704	4061245013701

**Order information: All versions also available in grey (EPDM) and red (silicone) Further lengths upon request.**

Further versions available



DEKTITE®  
Premium 3

## DEKTITE® EZi-Seal Set



### Application range

- > For waterproofing pipes on corrugated metal or fibre cement roofs

### Characteristics

- > Version EPDM (black)
- > Temperature resistance EPDM (black)  
permanent 50 °C to +115 °C, short-term up to +150 °C

### Advantages

- > Non-absorbent, closed-cell sealing surface
- > Seals under compression even on wet surfaces
- > Seals without use of a joint sealant through existing seal strip.
- > No interference of thermal elongation of pipes
- > No fatigue fractures
- > 20-year warranty on material

### Included in delivery

- 1 pipe flashing
- 1 self-drilling screw set - optionally folding blind rivet set

Cross references	Page
Joint sealant	124
Tightener	124
Hose clamp	125

### Assembly instruction



### Notice

Use folding blind rivets for fibre cement boards. Profile height max. 45 mm.

### Product in the online shop



Order description	For pipe diameter [mm]	Base [mm]	Roof pitch [°]	Content screws [pieces]	PU [set]	Price/1 [EUR]	Article number	EAN
DFE 100 EZ Set	0 – 35	100 x 100	0 – 60	8	1		8200004706	4061245013947
DFE 101 EZ Set	5 – 55	139 x 139	0 – 35	8	1		8200104706	4061245013794
DFE 103 EZ Set	5 – 127	221 x 221	0 – 35	16	1		8200304706	4061245013770
DFE 104 EZ Set	75 – 175	280 x 280	0 – 35	20	1		8200404706	4061245013756
DFE 106 EZ Set	125 – 230	363 x 363	0 – 35	28	1		8200604706	4061245013732
DFE 107 EZ Set	150 – 300	456 x 456	0 – 35	32	1		8200704706	4061245013718
DFE 109 EZ Set	230 – 508	681 x 681	0 – 35	40	1		8200904706	4061245013695

**Order information: Other dimensions upon request**

## DEKTITE® Soaker Set

**Application range**

- > For waterproofing pipes with large openings

**Properties**

- > Version EPDM (grey)
- > Temperature resistance EPDM (grey) permanent 50 °C to +115 °C, short-term up to +150 °C
- > Temperature resistance silikone (red) permanent 50 °C to +200 °C, short-term up to +250 °C

**Advantages**

- > Large base ensures optimum positioning
- > Reliable and easy installation
- > Seals pipe and roof in a single work step
- > Prevents rainwater back-up

**Notice**

Not usable on smooth surfaces.  
Profile height max. 45 mm.

**Included in delivery**

- 1 pipe flashing
- 1 cartridge of EJOPLAST joint sealant
- 1 self-drilling screw set

Cross references	Page
Joint sealant	124
Tightener	124
Hose clamp	125

**Assembly instruction****Product in the online shop**

Order description	For pipe diameter [mm]	Base [mm]	Roof pitch [°]	Content Cartridge [ml]	Content Screws [set]	PU [set]	Price/1 [EUR]	Article number	EAN
DF 602 G Set	75 – 155	410 x 360	0 – 60	80	30	1		8206024704	4061245013688
DF 603 G Set	114 – 254	485 x 460	0 – 60	80	36	1		8206034704	4061245013671
DF 605 G Set	254 – 406	708 x 635	0 – 60	310	52	1		8206054704	4061245013664
DF 606 G Set	380 – 610	1006 x 905	0 – 60	310	96	1		8206064704	4061245013657

**Order information:** All versions also available in red (silicone). Further lengths upon request.

## DEKTITE® Combo Set

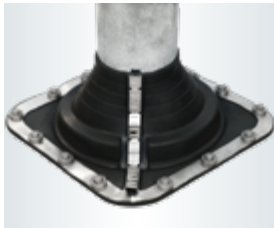

Cross references	Page
Joint sealant	124
Tightener	124
Hose clamp	125

### Assembly instruction



### Product in the online shop



### Application range

- > For sealing pipes on metal or fiber cement roofs
- > For subsequent waterproofing of pipes

### Properties

- > Version EPDM (black)
- > Temperature resistance EPDM (black or grey) permanent 50 °C to +115 °C, short-term up to +150 °C
- > Temperature resistance silicone (red) permanent 50 °C to +200 °C, short-term up to +250 °C

### Advantages

- > Perfect seal on roof and facade
- > No interference of thermal elongation of pipes
- > No fatigue fractures
- > Ideal for repairs of existing pipe systems
- > 20-year warranty on material

### Notice

Use folding blind rivets for fibre cement boards.  
Profile height max. 45 mm.

### Included in delivery

- 1 pipe flashing
- 1 cartridge of EJOPLAST joint sealant
- 1 self-drilling screw set - optionally folding blind rivet set
- 1 clips set

Order description	For pipe diameter [mm]	Base [mm]	Roof pitch [°]	Content Cartridge [ml]	Content Screws [pieces]	PU [set]	Price/1 [EUR]	Article number	EAN
DC 101 B Set	5 – 60	139 x 139	0 – 40	80	8	1		8201104704	4061245046846
DC 103 B Set	5 – 127	218 x 218	0 – 40	80	16	1		8201304704	4061245046853
DC 104 B Set	75 – 175	285 x 285	0 – 40	80	20	1		8201404704	4061245046860
DC 106 B Set	125 – 230	365 x 365	0 – 40	80	28	1		8220304704	4061245046877
DC 107 B Set	150 – 280	454 x 454	0 – 40	310	32	1		8230304704	4061245046884
DC 109 B Set	240 – 503	685 x 685	0 – 40	310	40	1		8250304704	4061245046891
DC 110 B Set	350 – 760	1000 x 1040	*	310	70/10	1		8270004704	4061245013572

\*350 - 500 mm cut: maximum 30°; 500 - 760 mm cut: maximum 15°

Order information: All versions also available in grey (EPDM) and red (silicone) Further lengths upon request.

## DEKTITE® Strip Flash Set

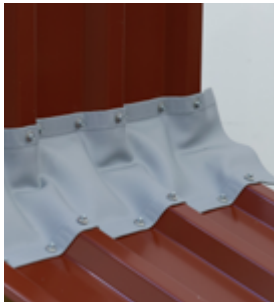
**Application range**

- > Sealing of wall joints
- > Forming expansion joints

**Properties**

- > Version TPE (grey)
- > Temperature resistance TPE (grey)  
permanent 50 °C to +115 °C, short-term up to +150 °C
- > Edge of sealing strip ≤ 25 %  
(accordion principle)
- > Use up to profile height ≤ 35 mm

**Scope of delivery DS3 235**

- 2 cartridges joint sealant  
(neutral curing silicone)

**Scope of delivery DS10 235**

- 5 cartridges joint sealant  
(neutral curing silicone)
- 1 self-drilling screw set

**Scope of delivery DS15 450**

- 10 cartridges joint sealant  
(neutral curing silicone)
- 1 self-drilling screw set

**Assembly instruction****Product in the online shop**

Order description	Length [m]	Width [mm]	Content Cartridge [ml]	Content Screws [pieces]	PU [set]	Price/1 [EUR]	Article number	EAN
DS3 235	3.1	235	310	134	1		8200006704	4061245013916
DS10 235	10.0	235	310	410	1		8200005704	4061245013930
DS15 450	15.0	450	310	670	1		8200002704	4061245013978

## EJOPLAST joint sealant



### Application range

- > For sealing the DEKTITE® pipe flashings

### Properties

- > Single-component universal sealant based on polycarboxylic acid copolymeric base
- > ACE 7 adheres to almost all surfaces (e.g. Steel, aluminium, copper, brass, glass, wood, ceramic, bitumen, concrete, masonry, plaster, plexiglas, tiles, roof tiles, polyester, roofing paper, etc.)
- > Immediately rainproof - workable in the rain
- > Excellent weather and UV resistance

### Technical specifications

Skin formation time at 23 °C/50 % rLf [min]	~ 1
Installation temperature: from/to [°C]	+ 5 / + 35
Viscosity at 23 °C	pasty
Density at 23 °C according to ISO 1183-1 [g/cm³]	~ 1,1
Permitted total deformation [%]	10
Temperature resistance from/to [°C]	- 20 / + 80
Shelf life at 23 °C/ 50 % rLf [months]	24*
Storage temperature from/to [°C]	0 / + 30
Volume shrinkage according to ISO 10563 [%]	~ 20

\*From production

### Product in the online shop



Order description	Contents [ml]	Colour	PU [pieces]	Price/1 [EUR]	Article number	EAN
EJOPLAST 310 ml clear	310	clear	1		8200001100	4061245093901

## Tightener/cable tie



### Application range

- > For reliable sealing between pipe and pipe flashing
- > For diameters from 150 mm onwards

### Order information

Universal hose clamp consisting of tightener and universal cable tie. Length of universal cable tie  $\geq$  pipe circumference + 50 mm.

### Installing the cable tie

Tip back the hinged screw in the tightener, insert one end of the cable tie through the tightener and twist about 15 mm Place universal cable tie around DEKTITE®, insert through the tightener and tighten by hand. Hinge the screw inwards and tighten as far as possible with a screwdriver.

### Technical specifications





## Product in the online shop



Order description	Width [mm]	Length [cm]	PU [set]	Price/1 [EUR]	Article number	EAN
Cable tie set (1 tightener + 1 cable tie 100 cm)	7	100	1		8200078300	4061245013824
Cable tie set (1 tightener + 1 cable tie 150 cm)	7	150	1		8200079300	4061245013817
Cable tie set (1 tightener + 1 cable tie 200 cm)	7	200	1		8200070300	4061245013855

Order description	Width [mm]	Length [cm]	PU [pieces]	Price/1 [EUR]	Article number	EAN
Tightener	-	-	1		8200077300	4061245013831
Cable tie (5000 cm)	7	5,000	1		8200076300	4061245013848

## Hose clamp



## Application range

- > For reliable sealing between pipe and pipe flashing

## Installation instruction

Pierce the marking for the clamp or cable tie at the joint, pull through, place around the DEKTITE® and close.

## Technical specifications



## Product in the online shop



Order description	For pipe diameter [mm]	PU [pieces]	Price/1 [EUR]	Article number	EAN
Hose clamp 20-32	20 – 32	1		8200004300	4061245013961
Hose clamp 40-60	40 – 60	1		8200006300	4061245013923
Hose clamp 60-80	60 – 80	1		8200008300	4061245013909
Hose clamp 70-90	70 – 90	1		8200009300	4061245013893
Hose clamp 90-110	90 – 110	1		8200011300	4061245013886
Hose clamp 110-130	110 – 130	1		8200013300	4061245013879
Hose clamp 130-150	130 – 150	1		8200015300	4061245013862

## Sealing washer E

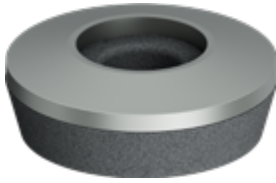

### Application range

- > Waterproofing
- > For improvement of the static and dynamic values
- > E38 and E50 to cover misdrills

### Properties

- > Metal back A2 stainless steel, thickness 1 mm
- > Bonded EPDM
- > Excellent weather and UV resistance

### Technical specifications

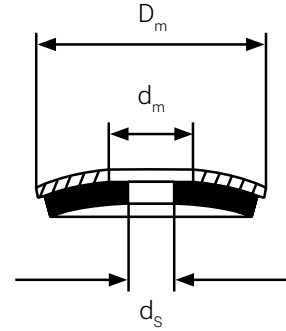

### Product in the online shop



Order description	D <sub>m</sub> [mm]	d <sub>m</sub> [mm]	d <sub>s</sub> [mm]	Elastomer thickness [mm]	For screws Ø [mm]	PU* [pieces]	Price/100 [EUR]	Article number	EAN
Sealing washer E11/2-5.7x1	11	5.7	4.0	2.0	4.8; 4.9; 5.5; DG40	100		3010092300	4061245020778
Sealing washer E14/3-5.7x1	14	5.7	4.0	3.0	4.8; 4.9; 5.5	100		3010077300	4061245020785
Sealing washer E14/3-6.8x1	14	6.8	4.9	3.0	6.0; 6.3; 6.5; 6.8	100		3010071300	4061245044897
Sealing washer E16/3-5.7x1	16	5.7	4.0	3.0	4.8; 4.9	100		3031067300	4061245044903
Sealing washer E16/3-6.8x1	16	6.8	4.0	3.0	5.5; 6.0; 6.3; 6.5; 6.8	100		3010067300	4061245020808
Sealing washer E16/3-7.8x1	16	7.8	5.7	3.0	7.2; 7.5; DG70	100		3030011300	4061245044910
Sealing washer E16/3-8.5x1	16	8.5	6.5	3.0	8.0	100		3030052300	4061245038827
Sealing washer E19/3-6.8x1	19	6.8	4.0	3.0	4.8; 5.5; 6.0; 5.5/6.3	100		3010066300	4061245020815
Sealing washer E19/3-6.8x1 internal hole 4.9 mm	19	6.8	4.9	3.0	6.3; 6.5; 6.8	100		3030066301	4061245044927
Sealing washer E19/3-7.8x1	19	7.8	5.7	3.0	7.2; 7.5	100		3030066300	4061245044934
Sealing washer E22/3-6.8x1	22	6.8	4.0	3.0	4.8; 4.9; 5.5; 6.0	100		3010013300	4061245020839
Sealing washer E22/3-6.8x1 internal hole 4.9 mm	22	6.8	4.9	3.0	6.3; 6.5; 6.8; 6.5/7.0	100		3030013301	4061245044941
Sealing washer E22/3-7.8x1	22	7.8	5.7	3.0	7.2; 7.5	100		3030013300	4061245044958
Sealing washer E22/3-8.5x1	22	8.5	7.0	3.0	8.0	100		3030053300	4061245038858
Sealing washer E29/6.8x1	29	6.8	4.0	3.0	5.5; 6.0; 6.3; 6.5; 6.8	100		3010015300	4061245020822
Sealing washer E29/8.5x1	29	8.5	7.0	3.0	7.2; 8.0	100		3030055300	4061245038865
Sealing washer E38-4	38	6.9	4.0	4.0	4.8; 5.5; 6.0; 5.5/6.3	10		3030073300	4061245020907
Sealing washer E50-4	51	6.9	4.0	4.0	4.8; 5.5; 6.0; 5.5/6.3	10		3030075300	4061245020914

\*The total order quantity per variant is delivered in a single carton. Delivery in individual PU available upon request.

## Mushroom washer

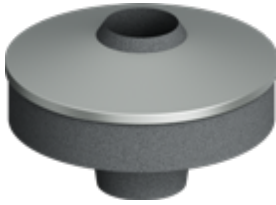

### Application range

- > For fixing light diffusing panels

### Properties

- > Metal back A2 stainless steel, thickness 1 mm
- > Moulded elastomer part
- > Pre-assembled on EJOT screws for JZ5, JA3

### Technical specifications

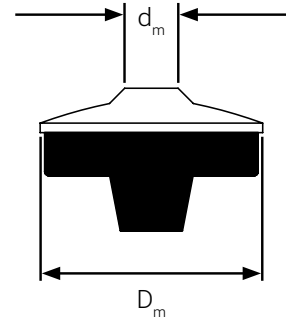

### Product in the online shop



Order description	Height [mm]	Collar diameter [mm]	D <sub>m</sub> [mm]	d <sub>m</sub> [mm]	PU [pieces]	Price/100 [EUR]	Article number	EAN
Mushroom washer EP 25	7.0	9.0	25	6.3	100		3010070704	4061245020792

## Shearing load washer VS

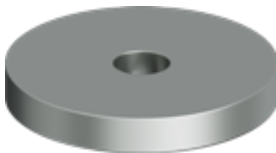

### Application range

- > For use with EJOT screws JZ, JA, JT

### Properties

- > Zinc-plated steel
- > Metal thickness 4 mm

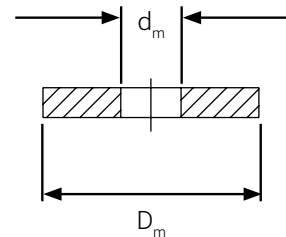

### Product in the online shop



Order description	D <sub>m</sub> [mm]	d <sub>m</sub> [mm]	PU [pieces]	Price/100 [EUR]	Article number	EAN
Shearing load washer VS 29	29	6.7	100		3010000003	4061245020846

## Thread protection sleeve



### Application range

- > For covering drill points and thread ends of EJOT screws
- > For screw diameters 4.2 mm / 4.8 mm / 5.5 mm / 6.0 mm / 6.3 mm / 6.5 mm

### Properties

- > Soft plastic

### Technical specifications

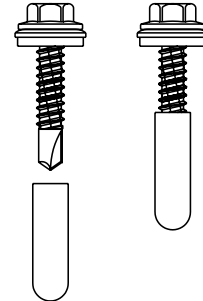

#### Which thread protection sleeve for which EJOT screw?

Screw	Thread protection sleeve
JT...-2-4.2	3.0x10
JF...-2H-4.8	3.0x10
JT...-2H-4.8	3.0x10
JT...-2-4.8	3.0x10
JT...-3-4.8	3.5x10
JT...-2H-5.5	3.5x10
JT...-2H-6.3	3.5x10
JT...-2H-Plus-5.5	4.0x10
JT...-3H-5.5	4.0x10
JT...-3-5.5	4.0x10
JF...-5.5	4.0x10
JF...-6.0	4.5x10

#### Which thread protection sleeve for which EJOT screw?

Screw	Thread protection sleeve
JT...-4-5.5	4.5x10
JT...-6-5.5	4.5x10
JT...-8-5.5	4.5x10
Dabo ...-4.8	4.5x25
JT...-12-5.5	4.5x25
JT...-18-5.5	4.5x25
JT...-3H-6.3	4.5x10
JT...-4-6.3	4.5x10
JT...-6-6.3	5.0x10
JT...-X-6.0	4.0x10
JZ...-6.3	5.5x10
JA...-6.5	5.5x10

### Product in the online shop



Order description	Internal Ø [mm]	Length [mm]	PU [pieces]	Price/100 [EUR]	Article number	EAN
<b>RAL 9002 (grey-white)</b>						
Thread protection sleeve 3.0x10 RAL 9002	3.0	10	1000		8200020700	4061245020600
Thread protection sleeve 3.5x10 RAL 9002	3.5	10	1000		8200021700	4061245020594
Thread protection sleeve 4.0x10 RAL 9002	4.0	10	1000		8200022700	4061245020587
Thread protection sleeve 4.5x10 RAL 9002	4.5	10	1000		8200023700	4061245020570
Thread protection sleeve 4.5x25 RAL 9002	4.5	25	1000		8200053700	4061245083926
Thread protection sleeve 5.0x10 RAL 9002	5.0	10	1000		8200024700	4061245020563
Thread protection sleeve 5.5x10 RAL 9002	5.5	10	1000		8200025700	4061245020556

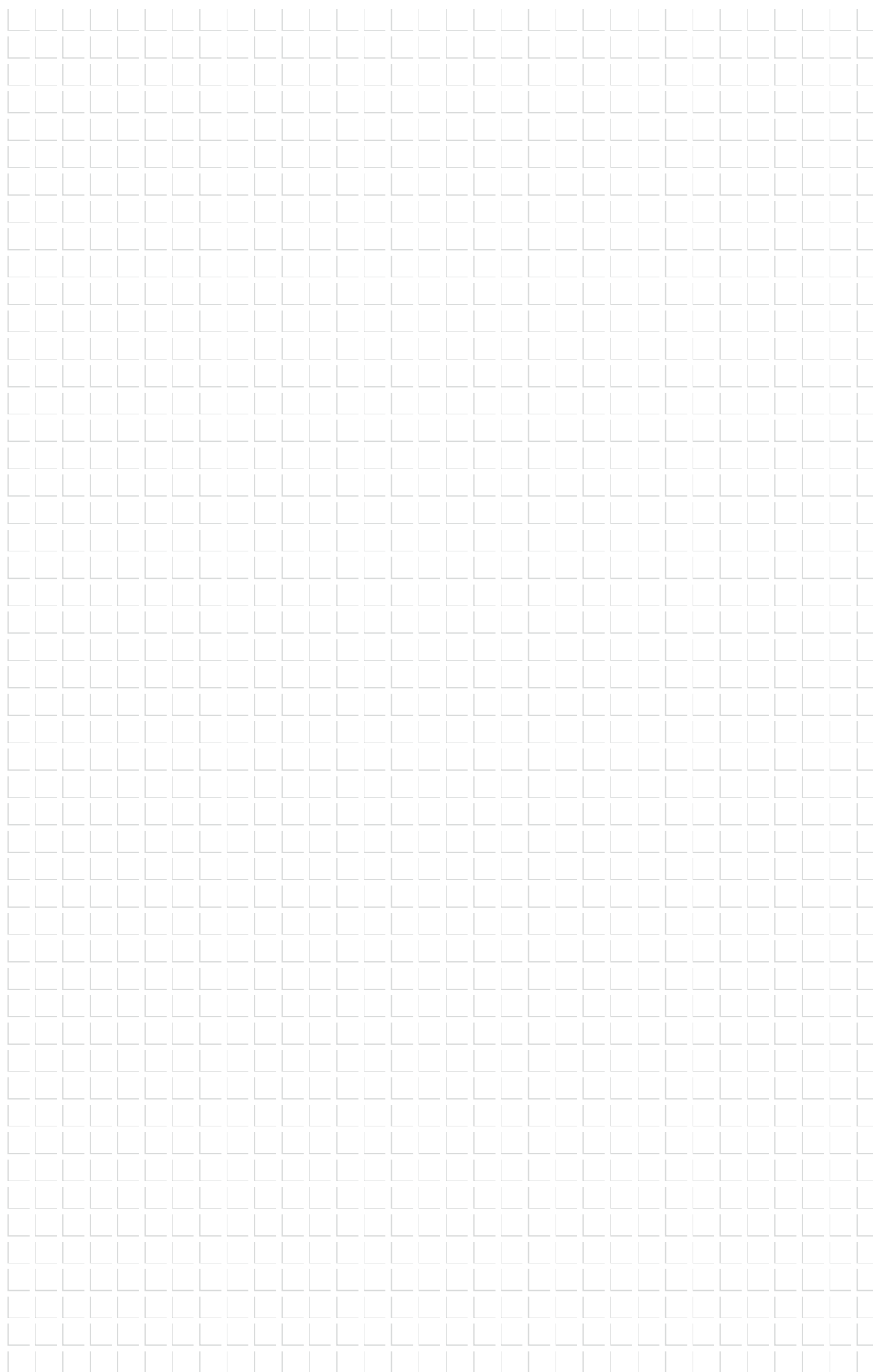

## TP310



### Application range

This joint sealing tape is suitable for joint constructions such as window couplings, concealed window connection joints or as a sealant border.

TP310 can also be used as filling tape - especially in metal construction. In this function it realises windproof and heat insulating properties. Corresponds to type 2 according to IFBS data sheet and BG 2.

### Technical specifications



### Properties

- > Open-cell flexible polyurethane foam impregnated with flame-retardant synthetic resin.
- > TP310 is manufactured without halogen-containing flame retardants, solvent-free and without using HCFCs/CFCs/CFCS
- > TP310 is supplied as compressed roll material, with one-sided self-adhesion in grey

### Please note

Do not expose the tape to direct sunlight permanently. The tape can be plastered / painted over. Illbruck silicone, acrylate and hybrid-based sealants are compatible with the tape. Further compatibilities can be requested from us. Sealing tape must be stored in a dry place until installation.

### Product in the online shop



Order description	Band width* [mm]	Application range [mm]	Roll length total [m]	Content roll [pieces]	PU [m]	Price/100 m [EUR]	Article number	EAN
Sealing tape TP310 10/1-2 grey	10	1 - 2	12,50	11	137,50		4331010102	4025109298499
Sealing tape TP310 10/2-4 grey	10	2 - 4	10,00	11	110,00		4331010204	4025109298536
Sealing tape TP310 12/3-6 grey	12	3 - 6	8,00	9	72,00		4331012306	4025109298574
Sealing tape TP310 15/1-2 grey	15	1 - 2	12,50	7	87,50		4331015102	4025109298512
Sealing tape TP310 15/2-4 grey	15	2 - 4	10,00	7	70,00		4331015204	4025109298550
Sealing tape TP310 15/3-6 grey	15	3 - 6	8,00	7	56,00		4331015306	4025109298598
Sealing tape TP310 15/4-10 grey	15	4 - 10	5,60	7	39,20		4331015410	4025109298635
Sealing tape TP310 15/5-12 grey	15	5 - 12	4,30	7	30,10		4331015512	4025109298673
Sealing tape TP310 20/4-10 grey	20	4 - 10	5,60	5	28,00		4331020410	4025109298659
Sealing tape TP310 20/5-12 grey	20	5 - 12	4,30	5	21,50		4331020512	4025109298703

\*Dimensional tolerances according to DIN7715 P3

## TP610



### Application range

This high-end joint sealing tape is used for the external driving rain-proof sealing of connection joints in building construction. TP610 is used in window installation, metal, wood and container construction.

Open-cell flexible polyurethane foam with polymer impregnate. Solvent-free single-sided self-adhesive to aid assembly. TP610 is manufactured without halogen-containing flame retardants, solvent-free and without using (H)CFC/CFCS.

### Characteristics

- > Impervious to driving rain 600 Pa and weather resistant with BG1 test
- > Vapor diffusible for drying out the joint
- > Wide range of dimension in two colours
- > EC1 PLUS and DGNB certified
- > For economical RAL quality-assured window installation
- > TP610 is supplied as compressed roll material, with one-sided self-adhesion in grey

### Please note

Weigh down residual rolls in opened cartons to avoid lateral opening (telescoping) of the rolls. The tape can be plastered and painted over. Compatibility should be tested when coating with light colors and sealants (white and transparent). The tape must not be exposed to or cleaned with solvent-based or aggressive chemicals. Sealing tape must be stored in a dry place until installation.

### Technical specifications



### Product in the online shop



Order description	Band width* [mm]	Application range [mm]	Roll length total [m]	Content roll [pieces]	PU [m]	Price/100 m [EUR]	Article number	EAN
Sealing tape TP610 10/2 anthracite	10	2	10,00	11	110,00		4361010200	4025109372106
Sealing tape TP610 15/2 anthracite	15	2	10,00	7	70,00		4361015200	4025109373103
Sealing tape TP610 15/3-4 anthracite	15	3 – 4	7,00	7	49,00		4361015304	4025109081695
Sealing tape TP610 15/4-5 anthracite	15	4 – 5	5,60	7	39,20		4361015405	4025109372151
Sealing tape TP610 15/5-7 anthracite	15	5 – 7	4,30	7	30,10		4361015507	4025109373158
Sealing tape TP610 20/2 anthracite	20	2	10,00	5	50,00		4361020200	4025109374155
Sealing tape TP610 20/3-4 grey	20	3 – 4	7,00	5	35,00		4361020304	4025109276152
Sealing tape TP610 20/4-5 anthracite	20	4 – 5	5,60	5	28,00		4361020405	4025109378153
Sealing tape TP610 20/5-7 anthracite	20	5 – 7	4,30	5	21,50		4361020507	4025109011791
Sealing tape TP610 20/7-11 anthracite	20	7 – 11	3,30	5	16,50		4361020711	4025109090758

\*Maßtoleranzen nach DIN7715 P3

## ISO-Zell PE Tape

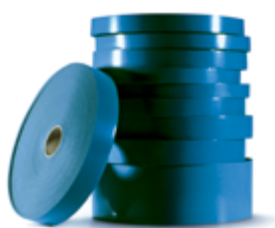

### Product description

ISO-ZELL PE Tapes are versatile sealing and padded tapes. These closed celled polyethylene foam tapes with their self-adhesive coating are characterised by a fine cellular structure and particularly by their flexibility.

### Application range

- For sealing, damping, insulating and cushioning in the areas of
- > Trapezoidal metal sheets and metal structures
  - > Solid, timber and prefabricated building constructions
  - > Window construction
  - > Drywall and partitioning
  - > Air conditioning and ventilation systems
  - > Domestic appliances
  - > Wagon and container construction
  - > Machine and equipment manufacturing

### Advantages

- > Flexible
- > Fine-pored
- > Water-repellent
- > High ageing resistance

### Technical specifications



### Product in the online shop



### Please note

ISO-ZELL PE tape must be stored in a dry place until installation.

Order description	Dimensions [mm]	Box content [rolls]	Metres per roll [m]	PU [m]	Price/100 m [EUR]	Article number	EAN
ISO-ZELL 2x20	2 x 20	120	20.0	2400		0070020020	4048368003932
ISO-ZELL 3x30	3 x 30	50	20.0	1000		0070030030	4048368004120
ISO-ZELL 3x50	3 x 50	25	20.0	500		0070030050	4048368004144

## ISO profile filler strips

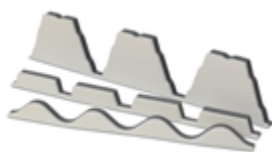

### Product description

ISO-PROFILE filler strips are profile-cut tapes of high-quality PE foam material. They are used in metal and industrial building structures to seal and insulate trapezoidal and wave profile sheets. They have the optimum form for a wide range of European-manufactured profiled metal sheeting.

### Application range

- > Reliable and permanent sealing of trapezoidal and corrugated metal sheeting
- > Sound and thermal insulation
- > Roofing applications (roof ridge, eaves)
- > Facade (parapet connections)

### Advantages

- > Available for many types of profiled sheets
- > Fine cells with a consistent smooth surface
- > Permanently elastic as well as having form stability
- > Fire protection classification B1 as a special property
- > Conforms to the requirements of the new IFBS guidelines for joint tightness on lightweight steel constructions
- > High and regularly examined product quality

### Technical specifications



### Certifications



### Notice

ISO-PROFILE filler strips must be stored in a dry place until installation.

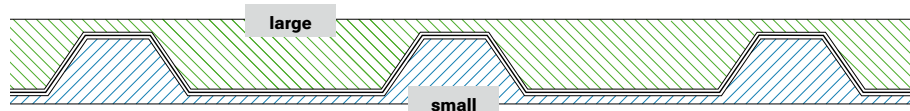

### Product in the online shop



Order description	Length [mm]	PU [pieces]	Price/m [EUR]	Article number	EAN
22 / 214 large - Maas / Laukien / Feilmeier	1070	1		0080022214	4048368174700
22 / 214 small - Maas / Laukien / Feilmeier	1070	1		0080122214	4048368174694
35 / 207 large - Fischer / Maas / Laukien / Feilmeier / Wurzer / SAB / Munker / Hoesch / Jorisode	1035	1		0080035207	4048368164701
35 / 207 small - Fischer / Maas / Laukien / Feilmeier / Wurzer / SAB / Munker / Hoesch / Jorisode	1035	1		0080135207	4048368164695
39 / 333 large - Arcelor / Munker	1000	1		0080039333	4048368166033
39 / 333 small - Arcelor / Munker	1000	1		0080139333	4048368164749
45 / 333 large - Maas / Laukien / Wurzer / SAB	1000	1		0080045333	4048368220902
45 / 333 small - Maas / Laukien / Wurzer / SAB	1000	1		0080145333	4048368220865
50 / 250 large - Maas / Laukien	1000	1		0080050250	4048368163537
50 / 250 small - Maas / Laukien	1000	1		0080150250	4048368163520
Fischer DL 40/333 large	1000	1		0080140333	4048368163216
ROMA 42 / 333 large	1000	1		0080042333	4048368165852
Brucha 42 / 333 large	1000	1		0080142333	4048368174526
Kingspan 35 / 333 large	1000	1		0080035333	4048368165746
Thyssen 35 / 333 large	1000	1		0080135333	4048368053722
Lattonedil 37 / 200 large	1000	1		0080037200	4048368186598
Corrugated sheet 18 / 76 - Maas / Laukien / Arcelor / Jorisode / Munker / SAB / Siegmetall	988	1		0080001876	4048368162158
Corrugated sheet 55 / 177 - Laukien / Eternit / Aluform	887	1		0080055177	4048368162356

Order information: Version with one-sided self-adhesive resp. UV-resistant aluminium lamination upon request

# Machinery Spare Parts Tools

## Cordless screwdriver ASCM 18 QSW AS

**Included in delivery**

- 1 ASCM 18 QSW AS  
(without battery pack or battery charger)
- 1 plastic tool case
- 1 scaffolding anchor
- 1 socket for hexagon screws SW 8
- 1 removable full metal drill chuck

**Application range**

- > Torque-optimized cordless screwgun with four gears for fixing metal with screw diameters of up to 6.0 mm

**Characteristics**

- > 4-gear full metal gear unit
- > Mechanical torque adjustment
- > Tool-free change of QuickIN attachments between applications in seconds
- > Brushless FEIN PowerDrive motor with 30 % higher efficiency enables longer service life
- > Compatible with AMPShare / Bosch Professional 18 V batteries

**Technical specifications**

Battery voltage	18 V
Li-Ion / ProCORE Li-Ion	Li-Ion / ProCORE Li-Ion
Motor	brushless
Gear	4-gear
Idle speed	400 / 700 / 1400 / 2500 1/min
Max. torque (hard/soft)	40 / 30 Nm
Torque levels	20 + 1
Drill chuck clamping range	1.5 – 13 mm
Screws	8 x 200 mm
Drill Ø timber	40 mm
Drill Ø steel	13 mm
Battery pack	not included in delivery

**3-year FEIN PLUS****Warranty**

including battery and charger  
(if registered online)

**Product in the online shop**

Order description	PU [pieces]	Price/1 [EUR]	Article number	EAN
4-gear cordless screwgun ASCM 18-QSW AS	1		9150660000	4014586898919
<b>Accessories</b>				
QuickIN Bithalter ASCM 18-4 QM AS / 18-QSW AS	1		9150610001	4014586404820
QuickIN Socket adapter ASCM 18-4 QM AS / 18-QSW AS	1		9150610002	4014586404844
QuickIN depth stop ASCM 18-4 QM AS / ASCM 18-QSW AS	1		9150610003	4014586476902

## Cordless impact screwdriver ASCD18-300 W2 AS



**Included in delivery**

- 1 ASCD 18-300 W2 AS (without battery pack or battery charger)
- 1 belt clip
- 1 bit holder
- 1 plastic tool case

**Application range**

- > Up to max. 290 Nm with brushless motor and torque adjustment in 6 stages
- > For the use of concrete screws (JC2, JBS-R and frame anchor)

**Characteristics**

- > For extremely precise work: electronic torque adjustment in 6 stages prevents screw heads from tearing off
- > Brushless FEIN PowerDrive motor with 30% higher degree of efficiency and long service life
- > 1/2 inch square for holding sockets. Robust solid metal impact gear
- > Metric screws up to M18 (8.8). Contact guard on gearbox head
- > 10% more torque in reverse running to loosen screws which are extremely tight
- > Compatible with AMPShare / Bosch Professional 18 V batteries

**Technical specifications**

Battery voltage	18 V
Battery compatibility	Li-Ion / ProCORE Li-Ion
Motor	Brushless
Idle speed	0 – 1700 rpm
Impacts	0 – 3400 rpm
Max. torque	290 Nm
Torque levels	6
Tool holder	1/2" external square
Max. metric screw	M18 (8.8)
Weight without battery	1.20 kg
Battery pack	Not included in delivery

**3-year FEIN PLUS Warranty**  
including battery and charger (if registered online)

**Product in the online shop**



Order description	PU [pieces]	Price/1 [EUR]	Article number	EAN
Cordless impact screwdriver ASCD18-300 W2 AS	1		9150620000	4014586898889

## Cordless hammer drill ABH 18-26 AS



### Included in delivery

- 1 ABH 18-26 AS  
(without battery pack or battery charger)
- 1 handle
- 1 depth stop
- 1 machine cloth
- 1 plastic tool case

### Application range

- > For drilling up to 26 mm in concrete

### Characteristics

- > Rapid work progress thanks to brushless motor with high impact energy – fast construction progress and high chisel removal rate
- > Protection for the user and tool by means of safety clutch and overload protection
- > Electronic Precision Control (EPC) - perfect handling and control for sensitive materials and challenging surfaces
- > Fatigue-free working thanks to compact design and few vibrations
- > Compatible with AMPShare / Bosch Professional 18 V batteries

### Technical specifications

Battery voltage	18 V
Battery compatibility	Li-Ion / ProCORE Li-Ion
Motor	Brushless
Idle speed	0 – 980 rpm
Impacts	0 – 4350 rpm
Impact energy	2.6 J
Tool holder	SDS-plus
Drill Ø concrete	26 mm
Drill Ø masonry	68 mm
Drill Ø steel	13 mm
Drill Ø timber	30 mm
Weight without battery	3.20 kg
Battery pack	Not included in delivery

**3-year FEIN PLUS  
Warranty**  
including battery and charger  
(if registered online)

### Product in the online shop



Order description	PU [pieces]	Price/1 [EUR]	Article number	EAN
Cordless hammer drill ABH 18-26 AS	1		9150650000	4014586897264

## ECORIV® ONE battery riveting tool 16.0V / 2.0 Ah



### Included in delivery

- 1 battery riveter ECORIV ONE
- 4 retention nosepieces
- 2 batteries 2.0 Ah
- 1 rapid charger 220 V
- 1 installation wrench
- 1 plastic transport box L-Boxx

Cross references	Page
Rivets	110

### Application range

- > For blind rivets made of aluminium, steel, copper and stainless steel up to Ø 5.0 mm
- > For folding blind rivets up to Ø 5.2 mm

### Advantages

- > Weight only 1.87 kg
- > Transparent recuperation tank
- > Powerful Li-Ion batteries with charge indicator
- > Riveting point illuminated by LEDs
- > Delivery with retention nosepieces for rivets 2.4 mm, 3.0/3.2 mm, 4.0 mm and 4.8/5.0 mm
- > High-quality fast battery recharger
- > Extended front sleeve optionally available
- > Special nosepieces are optional available

### Technical specifications

Working stroke	21 mm
Tensile force	10,000 N
Max. pin diameter	3.4 mm
Battery capacity 2.0 Ah (rivets per battery charge depending on type and material)	Up to 2,000 pieces
Charging time of battery 2.0 Ah	< 1 hour
Weight of riveting tool	1.54 kg
Weight of battery 16 V / 2.0 Ah	0.33 kg
Height (without battery)	approx. 24 cm
Length (incl recuperation tank)	approx. 28 cm

### Product in the online shop



Order description	PU [pieces]	Price/1 [EUR]	Article number	EAN
EJOT ECORIV ONE 16.0V / 2.0 Ah incl. 2 batteries	1		9150490190	4016111635136
<b>Accessories</b>				
EJOT rapid charger 220 V for ECORIV ONE	1		9150490195	4016111554970
EJOT battery ECORIV ONE 16V / 2.0 Ah	1		9150490105	4016111554956
EJOT retention nosepiece ECORIV ONE 2.4 mm	1		9150490196	4016111605078
EJOT retention nosepiece ECORIV ONE 3.0+3.2 mm	1		9150490197	4016111605085
EJOT retention nosepiece ECORIV ONE 4.0 mm	1		9150490192	4016111605092
EJOT retention nosepiece ECORIV ONE 4.8+5.0 mm	1		9150490193	4016111605108
EJOT folding blind rivet nosepiece ECORIV ONE 5.2 mm	1		9150490127	4016111517913
EJOT facade nosepiece ECORIV ONE 5.0 K11	1		9150490132	4016111161734
EJOT facade nosepiece ECORIV ONE 5.0 K14	1		9150490133	4016111161741
EJOT facade nosepiece ECORIV ONE 5.0 K16	1		9150490134	4016111232885

**Order information: ECORIV TWO upon request. Standard and special nosepieces upon request.**

## Precision drill bit HSS

**Application range**

- > For structural steel

**Properties**

- > Form S
- > Short spiral groove

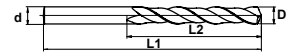
**Product in the online shop**

Order description	D [mm]	L1 [mm]	Rotation speed [rpm]	PU [pieces]	Price/1 [EUR]	Article number	EAN
Drill bit S 4.1/55	4.1	55	1,600	10		9250405000	4031093054782
Drill bit S 4.5/60	4.5	60	1,400	10		9250434000	4031093054904
Drill bit S 4.5/175	4.5	175	1,400	10		9250436000	4061245020136
Drill bit S 4.5/295	4.5	295	1,400	10		9250450295	4031093071550
Drill bit S 5.0/60	5.0	60	1,300	10		9250409000	4061245020280
Drill bit S 5.0/125	5.0	125	1,300	10		9250411000	4061245020273
Drill bit S 5.0/250	5.0	250	1,300	10		9250414000	4061245020259
Drill bit S 5.1/62	5.1	62	1,200	10		9250439000	4031093055093
Drill bit S 5.3/60	5.3	60	1,200	10		9250415000	4061245020242
Drill bit S 5.3/125	5.3	125	1,200	10		9250417000	4061245020235
Drill bit S 5.3/290	5.3	290	1,200	10		9250438000	4061245020129
Drill bit S 5.5/65	5.5	65	1,200	10		9250420000	4061245020211
Drill bit S 5.5/125	5.5	125	1,200	10		9250422000	4061245020204
Drill bit S 5.5/290	5.5	290	1,200	10		9250424000	4061245020181
Drill bit S 5.7/65	5.7	65	1,100	10		9250425000	4061245020174
Drill bit S 5.7/125	5.7	125	1,100	10		9250427000	4061245020167
Drill bit S 5.7/290	5.7	290	1,100	10		9250433000	4031093438230
Drill bit S 5.8/125	5.8	125	1,100	10		9250580125	4061245054148
Drill bit S 5.8/300	5.8	300	1,100	10		9250580300	4061245031347
Drill bit S 6.2/101	6.2	101	1,000	10		9250620101	4061245081113
Drill bit S 6.5/101	6.5	101	1,000	10		9250650101	4061245081120
Drill bit S 6.7/101	6.7	100	1,000	10		9250670101	4031093015790
Drill bit S 6.8/225	6.8	225	900	10		9250510000	4061245020051
Drill bit S 6.8/325	6.8	325	900	10		9250680325	4061245020044
Drill bit S 7.0/225	7.0	225	900	10		9250493000	4061245020112
Drill bit S 7.0/325	7.0	325	900	10		9250700325	4061245020037
Drill bit S 7.2/225	7.2	225	900	10		9250494000	4061245020105
Drill bit S 7.2/325	7.2	325	900	10		9250720325	4061245019970
Drill bit S 7.4/225	7.4	225	900	10		9250497000	4061245020099
Drill bit S 7.4/325	7.4	325	900	10		9250740325	4061245019963

## Hammer drill SDS plus®



### Application range

> For masonry, concrete, natural stone, artificial stone, etc.

### Advantages

- > Long service life
- > Centering point for easy, pinpoint drilling
- > Short spiral starts for optimised drill dust transport
- > Radially shaped reinforcement protection against hooking in case of reinforcement hits
- > 4x4 design allows precise concentricity and minimizes wear and friction losses
- > High-quality hardened and tempered steel for the toughest applications

### Technical specifications

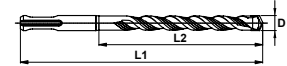

### Product in the online shop



Order description	D [mm]	L1 [mm]	L2 [mm]	PU [pieces]	Price/1 [EUR]	Article number	EAN
<b>4 edges</b>							
4 edge SDS-plus 5x160	5.0	160	100	1		9270005160	4061245080208
4-edge SDS-plus 5x260	5.0	260	200	1		9270005060	4061245080314
4-edge SDS-plus 5x410	5.0	410	350	1		9270005350	4061245080239
4-edge SDS-plus 6x160	6.0	160	100	1		9270006160	4061245080253
4-edge SDS-plus 6x260	6.0	260	200	1		9270006260	4061245080277
4-edge SDS-plus 8x160	8.0	160	100	1		9270008160	4061245080284
4-edge SDS-plus 8x260	8.0	260	200	1		9270008260	4061245080307
4-edge SDS-plus 8x360	8.0	360	300	1		9270008360	4061245080338
4-edge SDS-plus 8x600	8.0	600	540	1		9270008600	4061245080369
4-edge SDS-plus 10x160	10.0	160	100	1		9270010160	4061245080376
4-edge SDS-plus 10x260	10.0	260	200	1		9270010260	4061245080390
4-edge SDS-plus 10x360	10.0	360	300	1		9270010360	4061245081137
4-edge SDS-plus 10x460	10.0	460	400	1		9270010460	4061245080406
4-edge SDS-plus 12x160	12.0	160	100	1		9270012160	4061245081144
4-edge SDS-plus 12x260	12.0	260	200	1		9270012260	4061245081151
4-edge SDS-plus 14x160	14.0	160	100	1		9270014160	4061245081175
4-edge SDS-plus 14x310	14.0	310	250	1		9270014310	4061245081267
4-edge SDS-plus 15x160	15.0	160	100	1		9270015160	4061245081199
4-edge SDS-plus 16x260	16.0	260	200	1		9270016260	4061245081212

Further lengths upon request



## Socket wrench insert



### Application range

- > For fastening of all EJOT fasteners with hexagon head

### Characteristics

- > Clamping spring with ball
- > Secure fit of the screw

### Technical specifications



### Cross references

Cross references	Page
Cordless screwdriver ASCM QSW	135

Order description	Drive and Size	Length [mm]	PU [pieces]	Price/1 [EUR]	Article number	EAN
<b>Drive: 1/4" hexagon DIN/ISO 1173 - E 6.3</b>						
K-SW7-1/4"x50 with ball and flat spiral spring	SW7	50	1		9250705106	4061245019987
K-SW8-1/4"x50 with ball and flat spiral spring	SW8	50	1		9250705104	4061245020006
K-SW3/8"-1/4"x50 with ball and flat spiral spring	SW3/8"	50	1		9250705105	4061245019994
K-SW10-1/4"x50 with ball and flat spiral spring	SW10	50	1		9250705102	4061245020020
K-SW13-1/4"x50 with ball and flat spiral spring	SW13	50	1		9250705103	4061245020013
S-SW17-1/4"x65	SW17	65	1		9250705107	4061245021119

### Product in the online shop



## Hexalobular bit TX

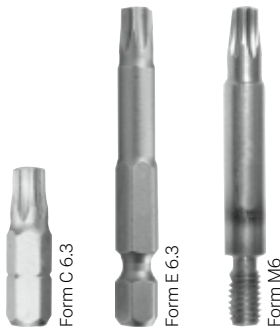

### Application range

> For fastening of all EJOT fasteners with hexalobular drive TX

### Technical specifications



### Product in the online shop



Order description	Drive and Size	Length [mm]	PU [pieces]	Price/1 [EUR]	Article number	EAN
<b>Drive: 1/4" hexagon DIN/ISO 1173 - C 6.3</b>						
TX20-1/4"/Cx25	TX20	25	1		9150010000	4050623100553
TX20W-1/4"/Cx25*	TX20W	25	1		9150008000	4050623100744
TX25-1/4"/Cx25	TX25	25	1		9150009000	4061245021072
TX25W-1/4"/Cx25*	TX25W	25	1		9150003000	4061245021102
TX30-1/4"/Cx25	TX30	25	1		9250431000	4050623100584
TX30W-1/4"/Cx25*	TX30W	25	1		9250431002	4050623100775
TX40-1/4"/Cx25	TX40	25	1		9250480000	4050623100591
<b>Drive: 1/4" hexagon DIN/ISO 1173 - E 6.3</b>						
TX25HF-1/4"/Ex50**	TX25	50	1		9506008401	4013288106926
TX25-1/4"/Ex300	TX25	300	1		9252014300	4061245075457
TX25-1/4"/Ex350	TX25	350	1		9252014350	4061245105611
TX30-1/4"/Ex50	TX30	50	1		9250431001	4050623102670
TX30-1/4"/Ex200	TX30	200	1		9253014200	4039161010975
TX30-1/4"/Ex350	TX30	350	1		9253014350	4061245021096
<b>Drive: threaded connection M6</b>						
TX25-M6x33	TX25	33	1		9250251425	4061245021089
TX30-M6x33	TX30	33	1		9250251430	4050623103936

\* Special bit: conical design for force fit at screw head of painted screws

\*\*Bit with holding function for unpainted screws

## Bit holder



Form E 6.3

### Application range

- > For attachment of all bits with drive form C

### Technical specifications



### Cross references

Cross references	Page
Cordless screwdriver	
ASCM QSW	135
Hexalobular bit TX	142

Order description	Length [mm]	PU [pieces]	Price/1 [EUR]	Article number	EAN
<b>Drive: 1/4" hexagon DIN/ISO 1173 - E 6.3</b>					
BT-1/4"-1/4"x57	57	1		9150506031	4050623800019
BT-1/4"-1/4"x250	250	1		9250010120	4061245021126

### Product in the online shop



## FR Tool



Form E 6.3

### Application range

- > For reliable fastening of corrugated and trapezoidal profiles with FR screws
- > For FR screws with sealing washers  $\varnothing$  11.0 mm

### Technical specifications



### Characteristics

- > Easy to use
- > Optimum installation in any position
- > Reliable screw guidance
- > Captive

### Advantages

- > For efficient fastening of corrugated and trapezoidal profiles
- > Fastener does not buckle to the side

### Cross references

Cross references	Page
Cordless screwdriver	
ASCM QSW	135

Order description	PU [pieces]	Price/1 [EUR]	Article number	EAN
<b>Drive: 1/4" hexagon DIN/ISO 1173 - E 6.3</b>				
EJOT FR Tool	1		9153600000	4061245061603
TX25-1/4"/Ex70	1		9150011000	4050623107200

### Product in the online shop



## FR pool - plastic



Form E 6.3

Cross references	Page
Cordless screwdriver ASCM QSW	135

### Application range

- > For reliable fastening of corrugated and trapezoidal profiles with FR screws
- > For FR screws without sealing washer or with sealing washer E11

### Characteristics

- > Easy to use
- > Optimum installation in any position
- > Reliable screw guidance
- > Captive

### Advantages

- > For efficient fastening of corrugated and trapezoidal profiles
- > Fastener does not buckle to the side

### Technical specifications



### Product in the online shop



Order description	PU [pieces]	Price/1 [EUR]	Article number	EAN
<b>Drive: 1/4" hexagon DIN/ISO 1173 - E 6.3</b>				
EJOT FR Tool plastic	1		9152600000	4061245020358

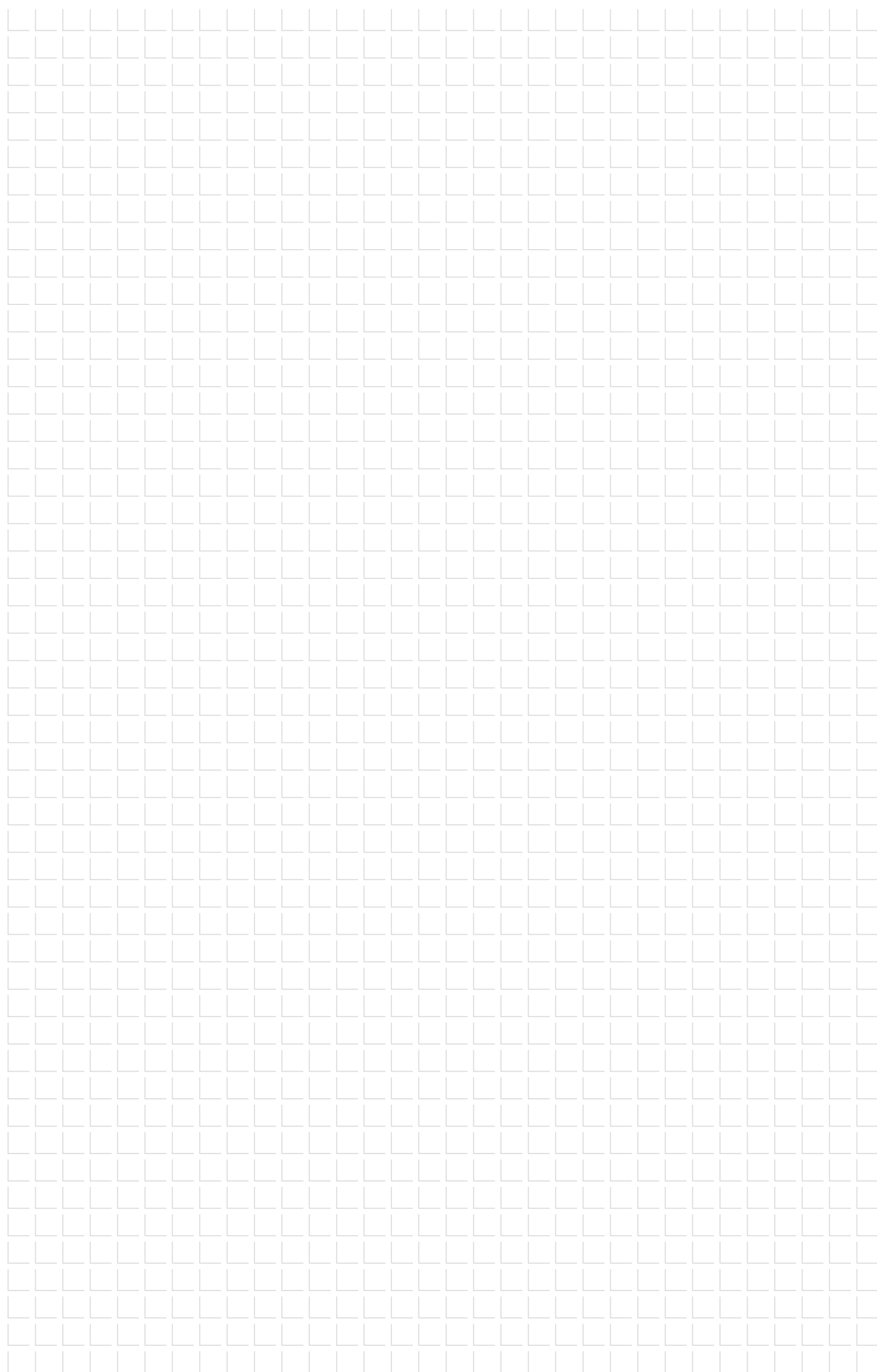



Tool for FR screws with sealing washer	Tool for screws without sealing washer	Diameter left-hand thread 4.9 mm	Diameter rivet setting head 9.5 mm	Height rivet setting head 1.5 mm	Diameter rivet-titting mandrel 2.7 mm	Diameter rivet shaft 4.8 mm	Drill hole diameter rivet 4.9 mm	Push-on cap TX white	Centring grommet XT	Effective shaft length 13 mm	Flat roofing anchor diameter 8.0 mm
Flat roof stress plate diameter 50.0 mm	Clamping thickness metal anchor 15.0 mm	Set screw diameter M12	Internal thread diameter M8	Threaded sleeve external diameter 10.0 mm	Insulation support anchor shaft diameter 8.0 mm	Insulation support anchor washer diameter 90 mm	Nylon anchor diameter 8.0 mm	Metal anchor diameter 8.0 mm	Tightening torque 60 Nm	Drive SDS plus	Drill with 4-cutting edge geometry 4-edge
PGM Masonry Drill Bit Certification Board [Manufacturer]	Sealing washer size and material E16	Drive cross recess H H2	Drive external cross recess H H2	Drive cross recess Z Z2	Drive external cross recess Z Z2	Drive internal square 5	Drive external square 5	Drive external triangular Triangular	Drive external hexagon SW8	Drive internal hexagon SW8	Drive external hexagon/hexalobular SW13/TX40
Drive hexalobular TX25	Drive external hexalobular TX25	Nominal drill diameter 10.0 mm	Drill hole diameter 10.0 mm	Drill hole depth 10 mm	Drill hole depth 10 mm	Nominal embedment depth $h_{nom}$ mm $\geq 70.0$	Effective embedment depth $h_{ef}$ mm $\geq 50.0$	Embedment depth $h_v$ mm $\geq 70.0$	Through hole component I $d$ mm 10.0	Slip resistance due to telescopic system	Slip resistance through support (metal-plastic)
Slip resistance through support (metal-metal)	Checked fastening element acc. to ETB guideline ETB	Resistance class of burglar-resistant components RC2	Waterproof	Protect from moisture	Stainless steel material EDDELSTAHL 0 Rost frei STAINLESS STEEL	Suitable for high-strength substructures	Also available as painted version	Values determined by the Passivhaus Institute	Fire performance class according to European standard and DIN A1	Fire resistant	Suitability according to seismic performance category
Top Coating C1000	Top Coating CLIMADUR	Top Coating EJO GUARD	EJO GUARD+ coating	Flat roof profile length 225.0 mm	Flat roof profile width 30.0 mm	Flat roof profile height 7.5 mm					

**Certifications**

ETA-10/0200 European Technical Assessment	Z-14.4-426 National technical approval abZ	Z-21.2-2122 General construction technique permit aBG	P-BWU02-168012 National technical test certificate abP	FM APPROVED FM Approval product certification by FM Global	EPD Environmental Product Declaration EPD	A+ Emission category according to French VOC directive	ICC ES International Code Council Evaluation Service	LEED TESTED LEED-tested	NSF Certified according to NSF/ANSI 61 drinking water system components

**Other**

Cross reference to previous page	Cross reference to next page	Online shop	Follow assembly instructions	Video



**EJOT SE & Co. KG**

**Market Unit Construction**

In der Stockwiese 35

57334 Bad Laasphe · Germany

T +49 2752 908-0

F +49 2752 908-731

[construction@ejot.com](mailto:construction@ejot.com)

[www.ejot.com/construction](http://www.ejot.com/construction)